

## **Study on Effects of Disc Cutter Sensors' Arrangement on Electrical Resistivity Survey**

\*Chang-Ho Hong<sup>1)</sup>, Gyu-Nam Jin<sup>2)</sup>, Gye-Chun Cho<sup>3)</sup>, Hee-Hwan Ryu<sup>4)</sup>,  
Kyoung-Yul Kim<sup>5)</sup>, Dae-Soo Lee<sup>6)</sup>,

<sup>1), 3)</sup> *Department of Civil Engineering, KAIST, Daejeon 34141, Korea*

<sup>2)</sup> *Land and Housing Institute, Korea Land and Housing Corporation (LH), Daejeon 34047, Korea*

<sup>4),5),6)</sup> *Power Transmission Laboratory, KEPCO, Daejeon 34056, Korea*

<sup>3)</sup> [gyechun@kaist.edu](mailto:gyechun@kaist.edu)

### **ABSTRACT**

Expectation of rapid change of ground in tunnel boring machine is difficult because tunnel face is not revealed. Probe drilling, tunnel seismic prediction (TSP), and tunnel electrical resistivity prospecting system (TEPS) are widely used TBM ahead prediction method. TEPS takes shortest time among these methods and has no influence on ground. In this study, disc cutter of TBM is utilized as sensor of TEPS and experimental test for checking influence of disc cutter spacing and contact area between disc cutter and ground.

### **1. INTRODUCTION**

Most of tunnels all around the world are constructed using tunnel boring machine (TBM) (mountain tunnel: over 60%, urban tunnel: over 80%, and subsea tunnel: over 80%, KICT,2010). Tunnel excavation using TBM has advantage compared to New Austrian Tunneling Method (NATM) such as low vibration and fast excavation (Cho et al., 2008; Lee, 2014). However, rapid change of ground condition and ground water inflow are hard to be treated because tunnel face of TBM is not exposed (Lee, 2014). Boring investigation is performed to estimate geological structure before tunnel excavation. However, boring log is not exact when the geological structure is complex or distance between bore holes is far. Therefore, evaluation of ground during tunnel

---

<sup>1)</sup> Graduate student

<sup>2)</sup> Senior research fellow

<sup>3)</sup> Professor

<sup>4)</sup> Senior researcher

<sup>5)</sup> Principal researcher

<sup>6)</sup> Chief researcher

excavation is necessary. Probe drilling, TSP (Tunnel Seismic Prediction), and TEPS (Tunnel Electrical resistivity Prospecting System) is commonly used Tunnel ahead prediction methods in TBM.

In this study, disc cutter is utilized as sensor of TEPS for continuous measurement. Electrical resistance is influenced by many factors such as sensor spacing and contact area of sensor and material. Influence of disc cutter spacing, contact area between disc cutter and ground are experimentally verified.

## 2. EXPERIMENTAL SETUP

### 2.1 Determination of test parameter

Disc cutters are arranged based on optimized ratio between disc cutter spacing and penetration depth. Measured electrical resistance also influenced by spacing of sensors and penetration depth or contact area. Therefore, influence of disc cutter spacing and contact area between disc cutter and ground on measured electrical resistance are verified for utilizing disc cutter as TEPS sensor. Disc cutter spacing and Contact area between disc cutter and ground are defined as Fig.1.

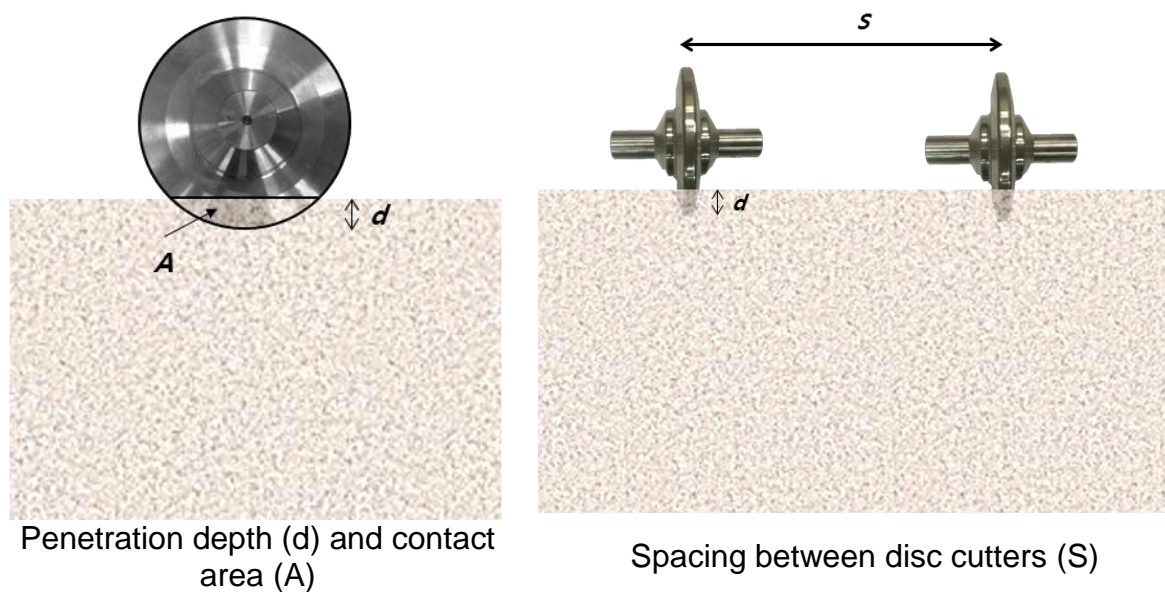

Fig. 1. Definition of test parameters

Detailed test parameters are determined based on  $\Phi 3,500$  TBM which is commonly used in South Korea. Disc cutter for TEPS sensor. Maximum distance is 2,000 mm except gauge cutter which is located perimeter of TBM cutter head and easily wears. Contact area is determined based on in-situ disc cutter penetration depth 5.27 mm (KICT, 2010). Disc cutter wears during excavation and penetration depth and contact area increase. Contact area in this study is 5,890, 8,412, and 10,426 mm<sup>2</sup> which is calculated with penetration depth 10, 20, and 30 mm, respectively, using Eq.1 assuming that disc cutter is disc with no thickness.

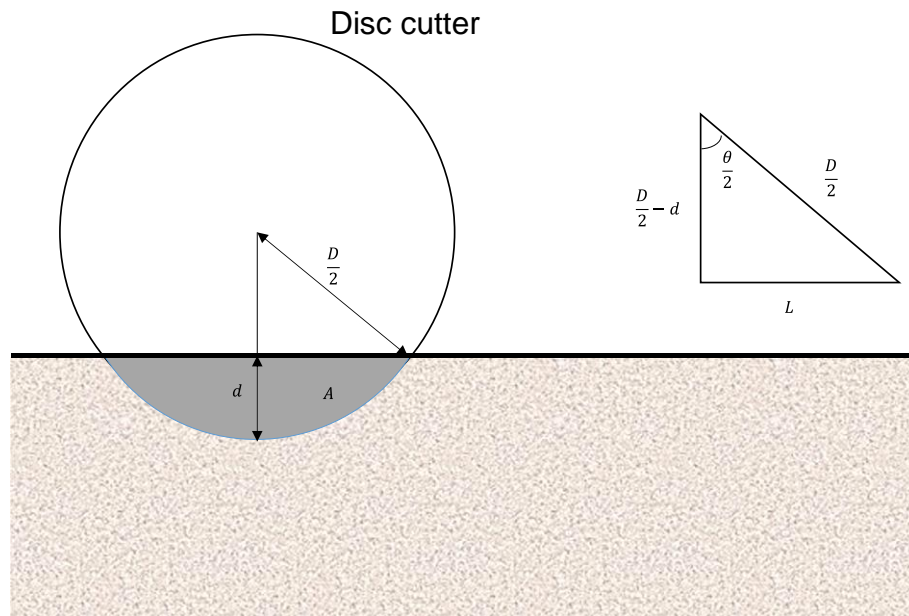

Fig. 2. Geometric parameters for contact area of disc cutter.

$$A = \frac{\pi D^2 \theta}{720} - 2L \cdot \left( \frac{D}{2} - d \right) \quad (1)$$

$$\text{where } \theta = \cos^{-1} \left( \frac{D^2 - 4d}{D^2 - 2d} \right), L = \sqrt{d(D - d)}$$

Test parameters are listed on Table. 1.

Table. 1. Test parameters

Contact area between disc cutter and ground [mm <sup>2</sup> ]	Spacing between disc cutters [mm]
5,890, 8,412, 10,426	200, 400, 600, 800, 1,000, 1,500, 2,000

## 2.2 Disc cutters for test

17 inch disc cutter weigh 120-300 kg (Jeong et al. 2014). Therefore, control of contact area and self-reliance of disc cutter is difficult. In this study, tests are performed using disc cutter whose diameter is one-third of original disc cutter. Disc cutter for this test is Fig. 3.

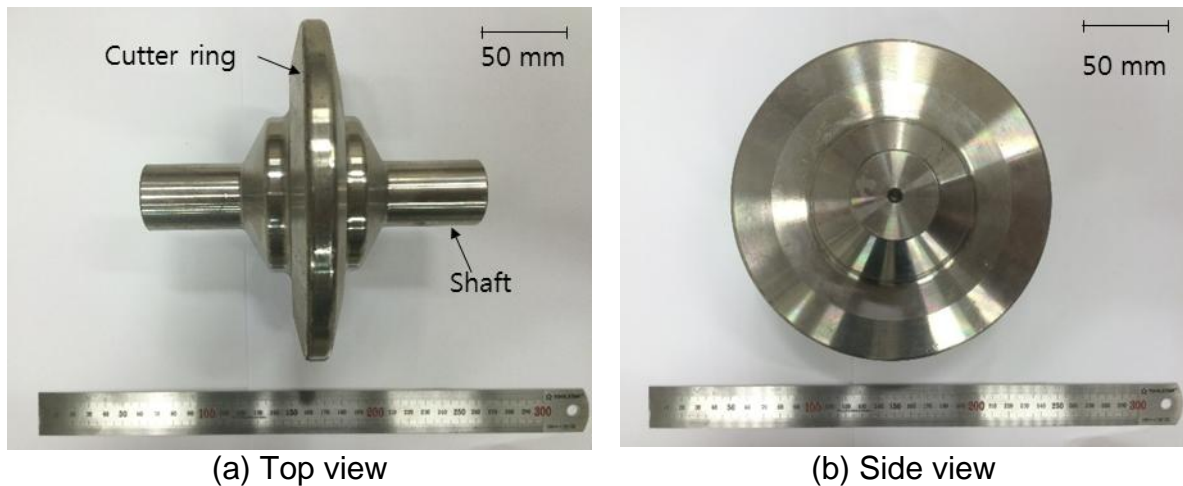

Fig. 3. Disc cutters for test

### 3. TEST RESULT

#### 3.1 Contact area between disc cutter and ground

Penetration depth of disc cutter changes with thrust force and torque of TBM. Electrical resistance decreases when contact area between sensor and ground whose electrical resistivity is constant increases (Samouëlian et al. 2005). It is necessary to check the influence of contact area between disc cutter and ground because decrement of electrical resistance varies with sensor shape and ground condition. Result is shown in Fig.4 with normalized electrical resistance because electrical resistance changes with disc cutter spacing.

Normalized electrical resistance reduces about 10% when 1,000 mm<sup>2</sup> of contact area increases ( $R^2=0.9248$ ).

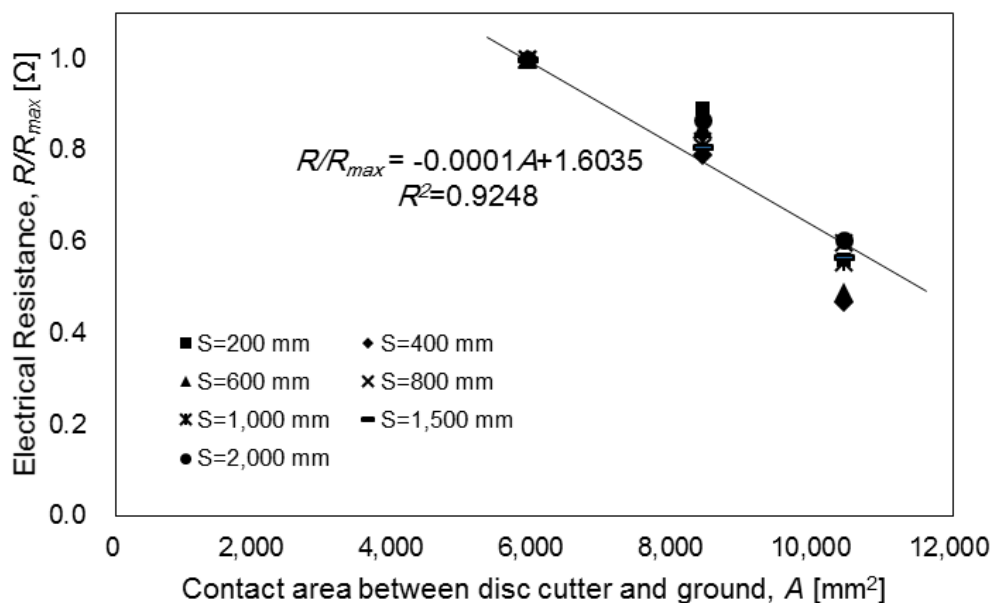

Fig. 4. Test setup and results with different contact areas.

### 3.2 Disc cutter spacing

Number and spacing of disc cutter are determined considering TBM type, TBM size, and ground condition. Electrical resistance increases when sensor spacing increases in general (Samouëlian et al., 2005). However, the increment of electrical resistance changes with various factors. Normalized electrical resistance is utilized for eliminating the effect of contact area between disc cutter and ground. Normalized electrical resistance increases about 10% when 1,000 mm of disc cutter spacing increases.

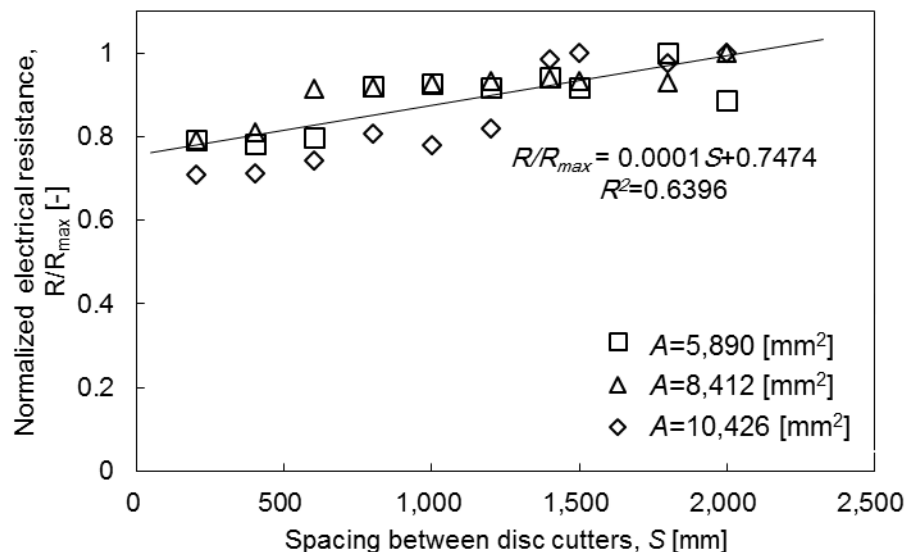

Fig. 6. Test setup and results with different disc cutters' spacing.

## 4. CONCLUSION

This study utilizes the disc cutters as sensor of TEPS and effect of disc cutter spacing and contact area is experimentally verified. The main conclusions of this study is stated as follows:

- 1) Contact area and spacing of sensor affects the measured electrical resistance of geophysical survey using electromagnetic waves. Disc cutters for test is one third in diameter of original disc cutter.
- 2) Contact area of disc cutter changes with ground condition, thrust force, and torque of TBM. Electrical resistance is affected by disc cutter spacing. Normalized electrical resistance decrease 10% when contact area 1,000 mm<sup>2</sup> increases.
- 3) Influence of disc cutter spacing on electrical resistance is important factor to select the disc cutter for sensor of TEPS. Normalized electrical resistance increases 10% when spacing between disc cutters increases 1,000 mm.

## **ACKNOWLEDGEMENT**

This work is financially supported by the "Development of key subsea tunneling technology" program (16SCIPB066321-03) funded by the Korea Agency for Infrastructure Technology Advancement (KAIA) and Korea Minister of Ministry of Land, Infrastructure and Transport (MOLIT) as 「U-City Master and Doctor Course Grant Program」

## **REFERENCES**

- Cho, J.W., Yu, S.H., Jeon, S., and Chang, S.H. (2008), "Numerical study on rock fragmentation by TBM disc cutter", *J. Korean Tunn. Assoc.*, **10**(2), 139-152
- Jeong, H.Y., Lee, S. Jeon, S. (2014), "Estimation of design parameters of TBM using punch penetration and Cerchar abrasiveness test", *J of Korean Tunn. Undergr. Sp. Assoc.*, **16**(2), 237-248.
- KICT (2010), "Planning research on TBM for Mechanized, Automated Tunnel Construction", *KAIA planning research report*.
- Lee, K.H (2014), "Prediction of Ground Conditions ahead of Tunnel Face Applicable to TBM", *Ph.D. dissertation*, Korea University, Seoul, South Korea.
- Ryu, H.H. (2010), "Development of a Tunnel Electrical Resistivity Prospecting System and its Application", *Ph.D. dissertation*, KAIST, Daejeon, South Korea.
- Samouëlian, A., Cousin, I., Tabbagh, A., Bruand, A., Richard, G. (2005), "Electrical resistivity survey in soil science: a review", *Soil & Tillage Research*, **82**, 173-193.