

An All-Optical Gain-Controlled Amplifier for Bidirectional Transmission

Bo-Hun Choi, Kyung-Jin Hong, Chang-Bong Kim, and Yong Hyub Won

A novel all-optical gain-controlled (AOGC) bidirectional amplifier is proposed and demonstrated in a compact structure. The AOGC function using fiber Bragg grating (FBG) pairs controls both directional signals independently, and combinations of optical interleavers and isolators suppress Rayleigh backscattering (RB) noise. The amplifier achieves high and constant gain with a wide dynamic input signal range and low noise figure. The performance does not depend on the input signal conditions, whether static-state or transient signals, or whether there is symmetric or asymmetric data traffic on bidirectional transmission. Transmission comparison experiments between invariable symmetrical and random variable asymmetric bidirectional data traffic verify that the all-optical gain control and bidirectional amplification functions are successfully combined into this proposed amplifier.

Keywords: Erbium-doped fiber amplifiers, gain, optical fiber communication, wavelength-division multiplexing.

I. Introduction

A bidirectional amplifier has been intensively studied to be applied to wavelength-interleaved bi-directional transmission, which can reduce not only nonlinear effects between adjacent channels, but also implementation cost by sharing one fiber for two transmission directions. One issue with a bidirectional amplifier is how to treat Rayleigh backscattering (RB) caused by the signal reflection [1], [3]. Normally the RB power is low, around -34 dB, but it rapidly increases when a bidirectional amplifier is used, so the power difference between an RB light and its parallel propagating signal decreases, as depicted in Fig. 1. Figures 1(a) and 1(b) show the RB generation in wavelength-interleaved bidirectional transmission, and the cross talk (around 14 dB) between a signal and RB noise in an optical spectrum, respectively. In order to solve this RB problem, several amplifiers have been proposed using a non-reciprocal optical filter [4], an arrayed waveguide grating (AWG) [5], a Mach-Zehnder wavelength division multiplexing (WDM) coupler [6], [7], a circulator [8], [9], two independent unidirectional amplifiers [10], [11], and an optical band pass filter [12]. The second issue is how to control both direction signal gains independently. It is common that signal inputs launched into both directions are asymmetric in optical bidirectional transmission systems. This asymmetry comes from the difference of channel numbers, the difference of channel powers, and the difference of transmission distances on both signal propagating directions. This is depicted in Fig. 2. An all-optical gain control (AOGC) method has the potential to manage this issue. However, to date it has been applied mainly to unidirectional transmission and has not been used on wavelength-interleaved bi-directional transmission [13]-[18]. Furthermore, these two issues mentioned above have not been studied together.

Manuscript received May 25, 2005; revised Sept. 12, 2005.

This work was supported in part by the Korea Ministry of Information and Communications, and the Korea Science and Engineering Foundation (KOSEF) through the Optical Internet Research Center (OIRC) Project.

Bo-Hun Choi (phone: +82 62 670 2429, email: adamchoi@gwangju.ac.kr) and Kyung-Jin Hong (email: tronichkj@gwangju.ac.kr) are with Division of Optical Communications and Electronic Engineering, College of Engineering, Gwangju University, Gwangju, Korea.

Chang-Bong Kim (email: aggie@kongju.ac.kr) is with Division of Information and Communication Engineering, Kongju National University, Chungnam, Korea.

Yong Hyub Won (email: yhwon@icu.ac.kr) is with School of Engineering, Information and Communications University, Daejeon, Korea.

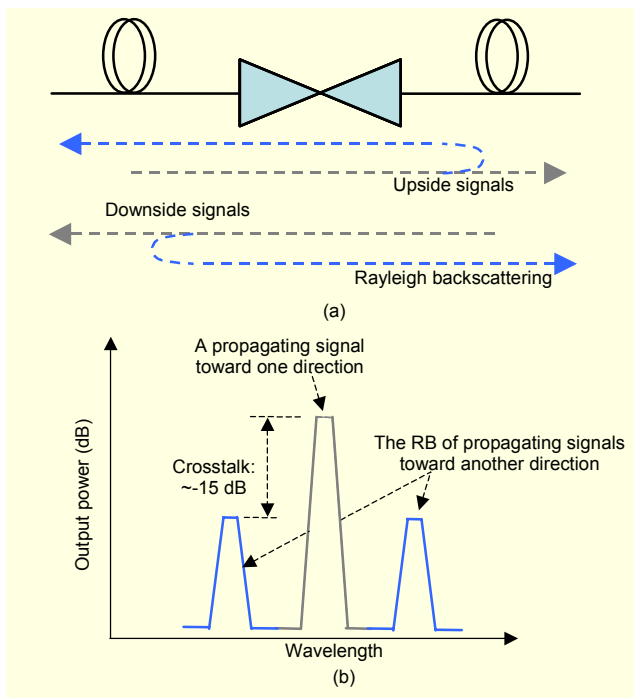

Fig. 1. (a) A schematic of RB generation with a bidirectional amplifier and (b) channel crosstalk of interleaved bidirectional WDM signals due to RB noise.

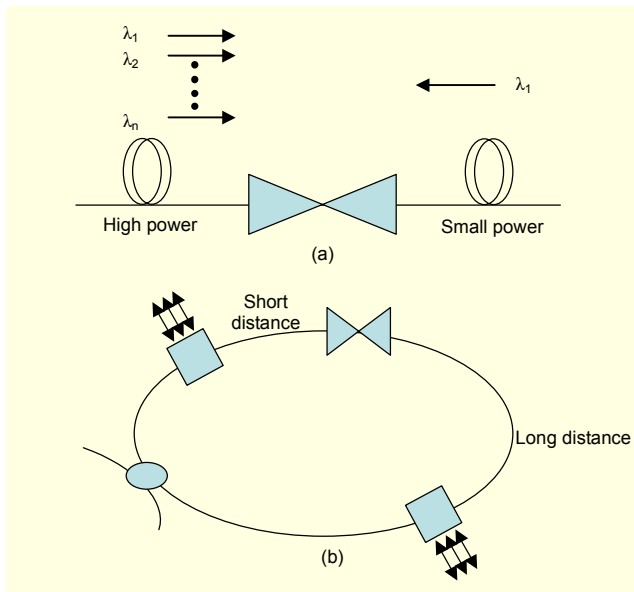

Fig. 2. (a) Channel number asymmetry and (b) distance asymmetry between both sides of a bidirectional amplifier that can generally happen.

In this paper, a novel structure for an asymmetrically bi-directional amplifier is proposed, which is composed of a two-staged erbium-doped fiber amplifier (EDFA) with AOGC function and an optical interleaving module in a compact structure. By combining two functions, RB noise removal and

bidirectional AOGC, the structure can accommodate additional modules for functions such as dispersion compensation, channel add/drop, and so on, while asymmetrically treating bi-directional signals without degradation of the amplifier performance. Also, the structure completely blocks lasing signals used for AOGC from propagating beyond the amplifier without needing additional devices. The amplifier has been optimized for high performance criteria such as high gain and low noise figure. The performance is investigated for static and transient input signals. The gain dynamics under asymmetric traffic are examined. Finally, this amplifier is applied to transmission experiments using randomly variable asymmetric bidirectional data traffic. The output spectrum and bit error rate (BER) measurement verify the successful removal of RB light and no gain change due to channel number variation.

II. Experiments

The experimental setup, as shown in Fig. 3(a), is composed of an interleaving module and two EDFAs, EDFA-A and EDFA-B, with only one shared 980 nm pump laser diode (LD). Figure 3(b) explains the simplified schematic, in which EDFA-A and EDFA-B themselves are bidirectional amplifiers, and an interleaving module is located between them. The cascaded amplification structure gives a high gain and wider dynamic gain range together, and the interleaving module has a role to reduce RB noise. Each EDF in the two EDFA modules is 16 m long with an absorption coefficient of 7.6 dB/m at 1530 nm, the length being optimized for gain. Odd and even WDM channels come from the A and B sides, respectively. Each direction signal experiences the first EDFA as a preamplifier, and proceeds into a different path consisting of an isolator and an attenuator through an optical interleaver of 100 GHz channel spacing, 2 dB insertion loss, and ± 15 ps/nm intra-channel dispersion. At the other interleaver, the signal is fed into a shared transmission line again, and is post-amplified by the other EDFA. Each EDFA has a lasing cavity composed of a 9:1 splitter, an attenuator, and a fiber Bragg grating (FBG) pair for an AOGC function. This structure gives the amplifier a low noise figure (NF) for pre-amplification and high NF for post-amplification, simultaneously [13]. So the overall NF of the amplifier becomes low.

It is necessary to block the lasing optical fields from propagating outside the cavities and disturbing other EDFAs. Thus, the lasing wavelengths were chosen differently from input signal wavelengths between even and odd numbers. The reflecting wavelengths of the FBGs in EDFA-A and EDFA-B are 1534.2 nm (even channel) and 1530.3 nm (odd channel), respectively, and their insertion losses are under 0.3 dB. Therefore, as shown in Fig. 4, the lasing light toward the other EDFA experiences a different path from the signals through an

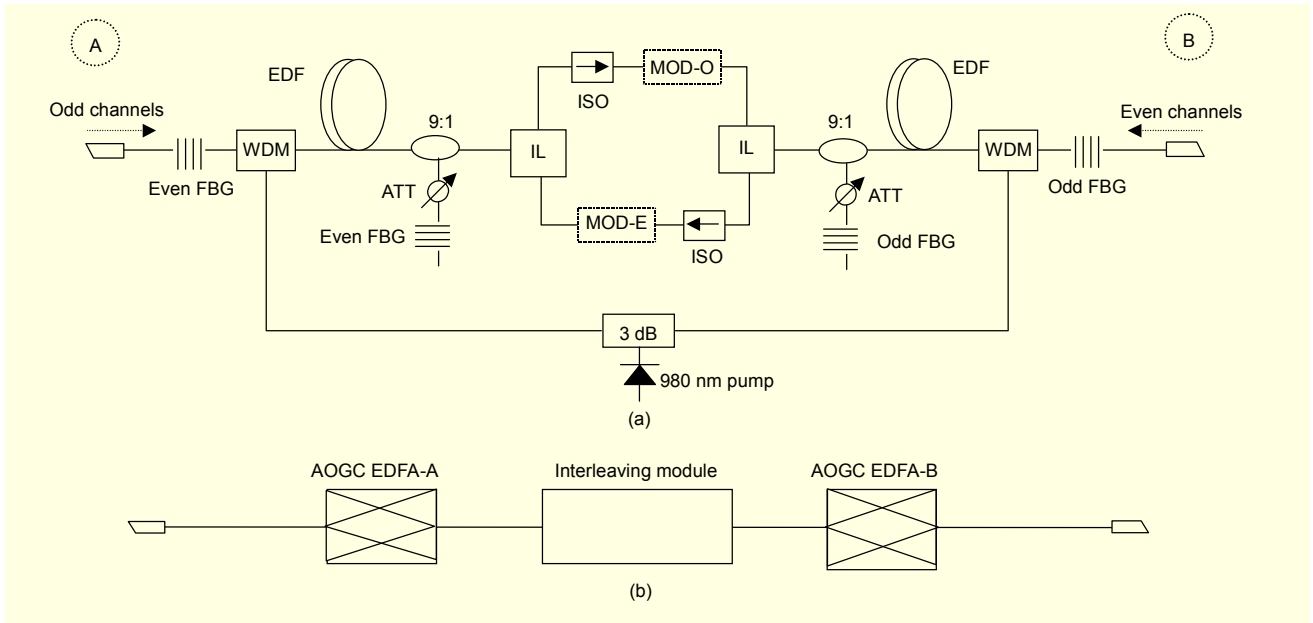

Fig. 3. (a) The experimental setup and (b) simplified schematic of the proposed amplifier. FBG: fiber Bragg grating, IL: optical interleaver, ISO: isolator, ATT: optical attenuator, EDF: erbium-doped fiber.

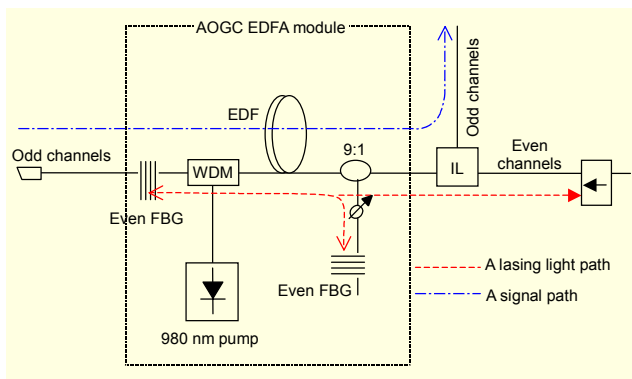

Fig. 4. A lasing optical field has a different path from signal fields through an optical interleaver, and is blocked by an isolator. Used FBGs have 99.9 % reflectivity.

interleaver and is blocked by an isolator. The lasing light toward an input port of the amplifier was rejected by an FBG with 99.9 % reflectivity. Additionally, in order not to permit even tiny power reflection at optical fiber connectors, connection points were fusion-spliced if possible, and angled physical contact connectors were used if connectors were needed in this setup.

III. Results

1. The Amplifier Module Characteristics

The measured gains and NFs of the proposed amplifier are shown in Fig. 5 together with those of two EDFAs inside the

amplifier. The gain of the EDFAs in Fig. 5(a) was clamped to 16 dB at 1555 nm as a preamplifier by controlling the lasing condition on the inside of the cavities with 70 mW optical pump power. It was kept constant up to 0 dBm input power within a 0.6 dB excursion. This dynamic range has a trade-off relation with constant gain level. The pre-amplified signal by one EDFA was attenuated by 10 dB and fed to the post-amplifier. This attenuation value was composed of 4.5 dB from two interleavers and an isolator, and 5.5 dB from MOD-E or MOD-O shown in Fig. 3(a). Optical attenuators were used to emulate these MOD-E and MOD-O, which correspond to additional modules including an add/drop module or a dispersion compensation fiber (DCF) module to be able to asymmetrically treat bidirectional signals. The net gain of the overall amplifier is 22.5 dB, identically for both directions, and the input signal dynamic range with 1 dB gain excursion is up to -6 dBm as shown in Fig. 3(b). The worst NF is 6.8 dB within the dynamic range. These values were measured at a 1555 nm signal wavelength with a single tone. It is believed that this NF is close to the optimized value, considering the influence of AOGC and bidirectional amplification to NF [9], [13], and [14]. This low NF results from the use of the selected lasing structure and the interleavers to suppress amplified spontaneous emission (ASE) between the two EDFAs. These results indicate that this bi-directional amplifier has high and constant gain with a wide dynamic range of input signal and low noise figure in the simplified structure compared to the previous results [13], [14], and [17]. Moreover, add/drop or DCF modules, etc..., can be merged into this amplifier without the present performance degradation.

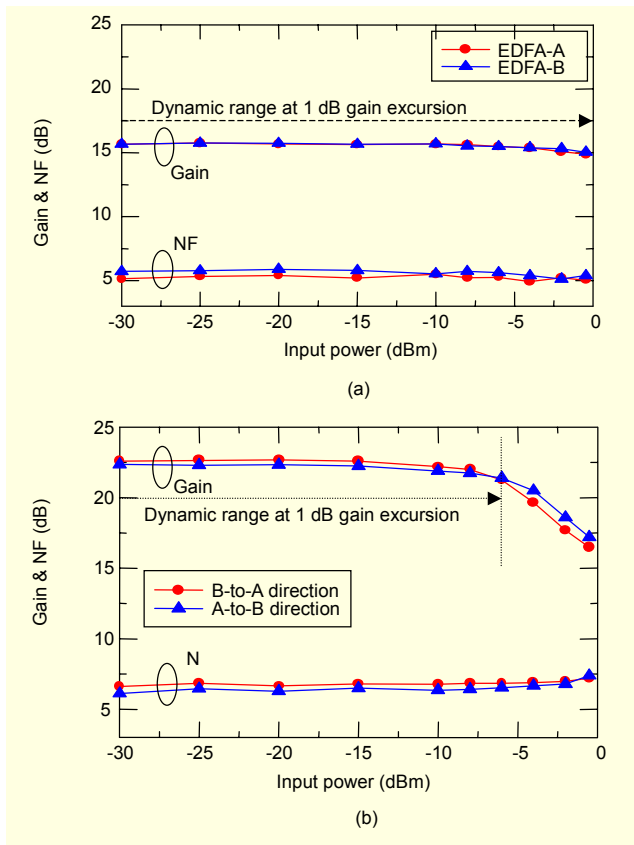

Fig. 5. The measured gain and NF of (a) EDFA-A and EDFA-B and (b) the overall amplifier at input power between -30 and 0 dBm.

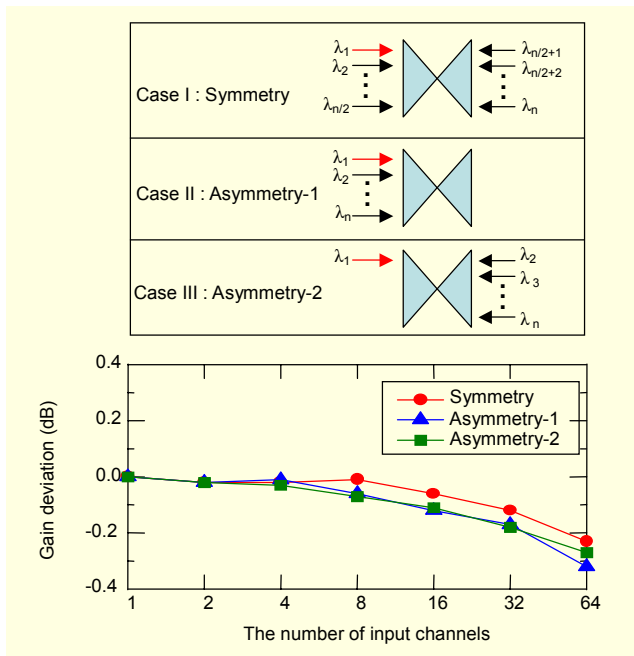

Fig. 6. The gain deviation according to three different signal inputs in symmetric or asymmetric (asymmetry-1 and asymmetry-2) data traffic.

The gain variation according to three different signal inputs was investigated to consider asymmetric data traffic, as shown in Fig. 6. The table in Fig. 6 presents the input signal conditions, in which λ_1 is a measured signal and the number “n” means the total used signal number. In the experiment, the single channel power was -25 dBm, and the powers of two saturation tones (ST) to replace a number of WDM signals were varied according to a required total channel number between 2 and 64. For symmetric data traffic (Case I), the sum power of a measured signal (1554.9 nm) and ST (ST-1, 1550.1 nm) on one side was identical to another ST (ST-2, 1550.9 nm) on the other side. For extremely asymmetric traffic, all channels have the same direction (Case II), or all channels have the opposite direction (Case III) except for one measured channel. The resultant gain deviations are around 0.3 dB for three different cases at -7 dBm input power of 64 channels, and are not affected by the asymmetry of the input signals. If these amplifiers are cascaded for long distance transmission, this gain deviation value will be one of the important system specifications because the worst accumulated gain deviation at the final destination is proportional to the value and the number of the amplifiers to be passed [15].

The transient response of the result in Fig. 6 was measured, and is shown in Fig. 7. For the worst case scenario, 63 of 64 WDM channels were added and dropped at 1 kHz frequency by using direct modulation, as shown in the downside of Fig. 7. The maximum gain variation is 0.4 dB to include an overshoot and undershoot of less than 0.1 dB. It is not different from the steady-state gain variation experiments in Figs. 5 and 6. The relaxation oscillation frequencies are 58 and 75 kHz on signal addition and drop, respectively [16], [18]. The consistent result explains that the gain in steady-state and transient response is satisfactorily controlled by AOGC. Thus, this amplifier is able to be used on bidirectional transmission not only to have asymmetric transmission distances, but also to use asymmetric

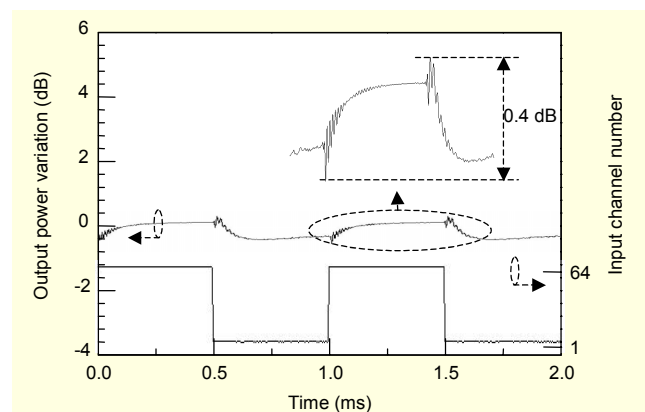

Fig. 7. The transient response of the output power of the surviving channel when 63 of 64 WDM channels were added and dropped with 1 kHz frequency.

signal powers, as explained in Fig. 2.

2. The Amplifier Application on Bidirectional Transmission

This amplifier was applied to bidirectional transmission experiments for the output spectrum and BER measurement. The experimental setup was presented in Fig. 8. Six odd channels between 1549.3 and 1557.3 nm, and six even channels between 1550.1 and 1558.1 nm with 100 GHz channel spacing were launched from both sides into this amplifier placed in the middle of two 26.4 km single mode fiber (SMF) spools. 10 Gb/s NRZ data was generated at each channel using a Mach-Zehnder modulator and 10^{23} -1 pseudo random bit sequence (PRBS). After they were transmitted through another 26.4 km SMF followed by DCF, the signals were measured. The transmission length was long enough for the RB light to be induced.

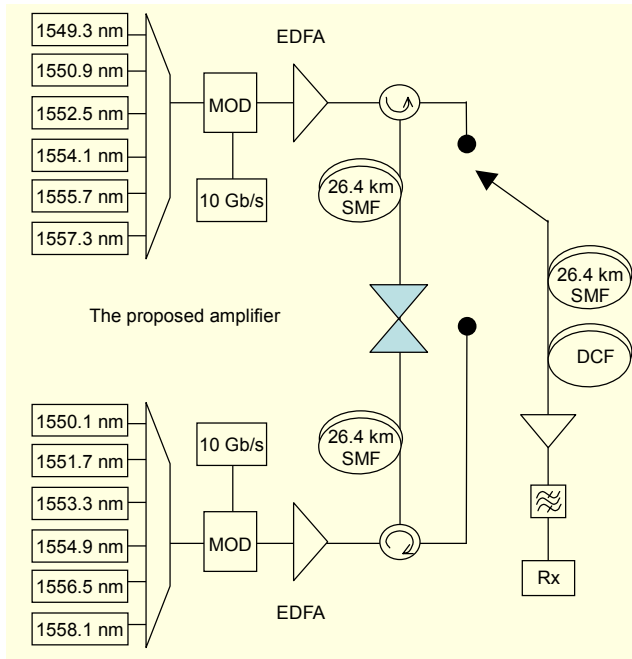

Fig. 8. The transmission experiment setup. MOD: modulator, PM: power meter, SMF: single mode fiber, DCF: dispersion compensation fiber.

The optical spectra were measured after the transmission, and the results are given in Fig. 9. Figures 9(a) and 9(b) show the signal output spectra for odd and even channels, respectively, at both sides. In each direction, two different cases were measured and compared between a case where all twelve channels were turned on (the dashed blue line) and a case where all channels except for one were turned off (the solid red line). The results showed a constant gain whether the channel number is twelve or one, and this WMD signal experiment was

consistent with the results of Fig. 5 and 6 using saturation tones. The small signals seen between high power signals are the RB of the optical signal propagating in the opposite direction. The RB level was well suppressed down to the ASE level of the EDFA, and the results on both directions were identical. The crosstalk between adjacent bidirectional channels is around -30 dB. This means that our design using optical interleavers and isolators rejects RB lights effectively. Figures 9(c) and 9(d) show measured spectra at around the lasing light wavelength for both sides. A tiny mark is shown at the wavelength used as a lasing light. These spectra indicate that lasing lights used for an AOGC function were successfully isolated inside each EDFA.

The BER measurement is shown in Fig. 10. Three channels were measured among six channels for each direction on symmetric bidirectional transmission. There are no error floors among the channels. The power penalty is below 0.5 dB at 10^{-9} error probability. The power penalty is considered to be within measurement error range, when taking into account that a back-to-back BER was measured directly from the source to the receiver without transmission line.

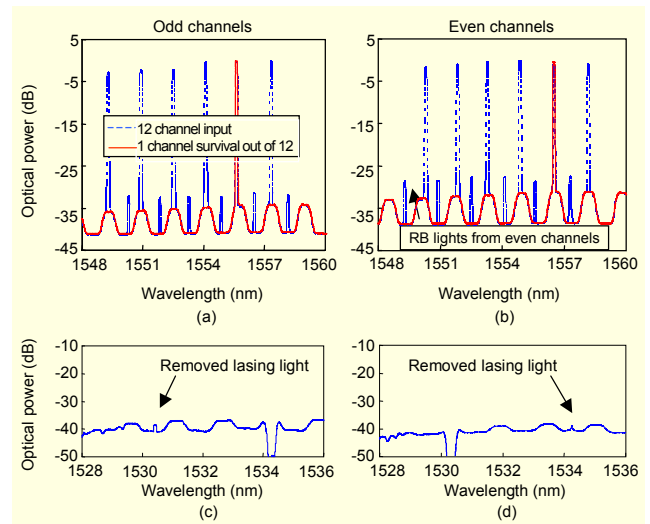

Fig. 9. The measured optical spectra for (a) odd and (b) even signal channels after transmission. The dashed line is for the case where all twelve channels were turned on, and the solid line is for the case where all channels were turned off except one channel. (c) and (d) show the optical spectra of even channel and odd channel output ports, respectively, at around lasing light wavelengths.

3. Amplifier Application on Asymmetric Bidirectional Transmission with Random Variable Data Traffic

If burst mode signal traffic is considered on the transmission, the amplifier is required to be applied not only to fixed asymmetric traffic, but also to randomly variable asymmetric data traffic. The setup and experimental conditions in Fig. 8

were used for this purpose. Additionally, five channels among all six channels were independently turned on and off at a low frequency modulation speed, as shown in Fig. 11(a), while all channels were modulated at 10 Gb/s. To make the random variable bidirectional data traffic, one traffic form among various forms of traffic was arbitrarily chosen as a general traffic pattern, as shown in Fig. 11(b). This traffic pattern is a random mixture of six different power levels according to the surviving channel number between one and six. The highest power means all six channels are turned on at both directions and the lowest power means only one channel is turned on. The BERs of a channel of no low-frequency modulation were measured while the traffic pattern from the other channels was periodically repeated with frequencies (f_c) between 200 Hz, 500 Hz, 1 kHz, and 75 kHz. Thus, the input power into the amplifier was changed to between -18 and -10 dBm.

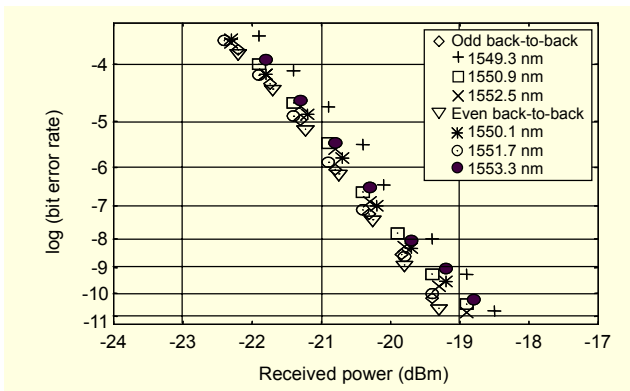

Fig. 10. Bit error measurement for three odd and three even channels on 80 km SMF symmetric bidirectional transmission.

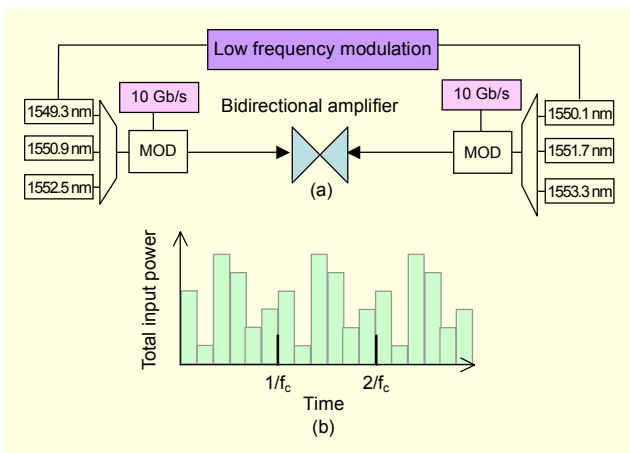

Fig. 11. (a) A schematic of BER measurement experiments for random variable asymmetric bidirectional data traffic. Five channels among all six channels were independently turned on and off at a low frequency modulation speed, and (b) a random mixture pattern of six different power levels was made.

The result is given in Fig. 12. The back-to-back BER was measured by the surviving channel after the transmission without the other signals. There were no signal degradations except for a 1 dB power penalty at 10^{-9} error probability, even at the relaxation frequency of this bi-directional amplifier, 75 kHz, which was measured in Fig. 7. This penalty came from the remaining gain fluctuation after the usage of AOGC. The results show that the amplifier keeps its performance unchanged in a dynamic data traffic change of bi-directional transmission.

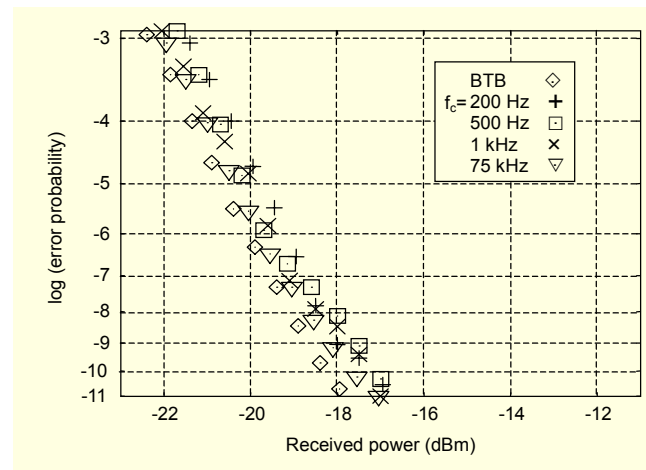

Fig. 12. The BERs of a surviving channel were measured while the random data traffic composed of six 10 Gb/s WDM channels was repeated with the frequency (f_c) between 200 Hz, 500 Hz, 1 kHz, and 75 kHz. BTB: back-to-back BER.

IV. Conclusion

A bidirectional amplifier with both an AOGC function and RB suppression was proposed and demonstrated in a simplified structure. It was composed of two EDFAs, which have lasing cavities using FBG pairs for AOGC, and a combination of optical interleavers and isolators to reduce RB noise. The amplifier achieved a high and constant gain of 22 dB with a 0.3 dB gain excursion up to -6 dBm input power. The worst NF was 6.8 dB even though AOGC and a two-stage amplification configuration were used together. The gain value was stably maintained under serious asymmetric bidirectional input signal variations from one to 64 channels, and there was no difference between the static and transient responses of the gain. The amplifier structure satisfactorily removed RB light to -30 dB and simultaneously confined lasing lights of AOGC in each EDFA. Transmission experiments for invariable symmetrical traffic and randomly variable asymmetric data traffic showed no signal degradation except at best 0.5 dB and 1 dB power penalties, respectively, at 10^{-9} error probability.

Acknowledgement

I wish to thank the Photonics Research Laboratory, in the Department of Electrical and Electronic Engineering, The University of Melbourne, Australia, for their help.

References

- [1] R.K. Staubli and P. Gysel, "Crosstalk Penalties Due to Coherent Rayleigh Noise in Bidirectional Optical Communication Systems," *IEEE J. Lightwave Technology*, vol. 9, no. 3, 1991, pp. 375-380.
- [2] Bo-Hun Choi, Moo-Jung Chu, Hyo-Hoon Park, and Jong-Hyun Lee, "Performances of Erbium-Doped Fiber Amplifier Using 1530nm-Band Pump for Long Wavelength Multichannel Amplification," *ETRI J.*, vol. 23, no. 1, 2001, pp. 1-8.
- [3] W.J. Chung, H.S. Seo, B.J. Park, J.T. Ahn, and Y.G. Choi, "Selenide Glass Optical Fiber Doped with Pr³⁵ for U-Band Optical Amplifier," *ETRI J.*, vol. 27, no. 4, Aug. 2005, pp. 411-417.
- [4] T.-W. Oh, J.-H. Shin, H.D. Kim, C.-H. Lee, M.S. Lee, and B.Y. Kim, "Bidirectional Erbium-Doped Fibre Amplifier with Non-reciprocal Optical Filter," *Electron. Lett.*, vol. 37, no. 5, 2001, pp. 283-284.
- [5] J.-W. Park and C.-H. Lee, "Wavelength Interleaved Bidirectional Add/Drop Amplifier Module," *IEEE Photon. Technol. Lett.*, vol. 12, no. 2, 2000, pp. 326-328.
- [6] M. Sumida, H. Maeda, and Y. Tada, "Asymmetric Bi-directional WDM Transmission of 8 (total) 10 Gbit/s Channels Using Bi-directional Amplifier Comprising Single Unidirectional Optical Amplifier and Four-port Mach-Zehnder WDM Coupler," *Electron. Lett.*, vol. 36, no. 20, 2000, pp. 1722-1724.
- [7] M. Sumida, H. Maeda, and T. Imai, "Ten-repeated Bi-directional WDM Transmission of Eight Channels at 10 Gbit/s Using Single-wavelength-Band-operating Bi-directional Amplifiers," *Electron. Lett.*, vol. 37, no. 13, 2001, pp. 850-852.
- [8] C.W. Bamard, J. Chrostowski, and M. Kavehrad, "Bidirectional Fiber Amplifiers," *IEEE Photon. Technol. Lett.*, vol. 4, no. 8, 1992, pp. 911-913.
- [9] H.D. Kim, J.-H. Shin, S.-T. Hwang, Y.J. Oh, and C.-H. Lee, "Bidirectional Amplifier Employing the Bidirectional Dispersion Compensation Technique," *IEEE Photon. Technol. Lett.*, vol. 13, 2001, pp. 746-747.
- [10] K.-I. Suzuki, H. Masuda, S. Kawai, K. Aida, and K. Nakagawa, "Bidirectional IO-channel 2.5 Gbit/s WDM Transmission over 250 km Using 76 nm (1531-1607 nm) Gain-band Bidirectional Erbium-doped Fibre Amplifiers," *Electron. Lett.*, vol. 33, no. 23, 1997, pp. 1967-1968.
- [11] J. Kani, M. Jinno, T. Sakamoto, K. Hattori, and K. Oguchi, "Bidirectional Transmission to Suppress Interwavelength-Band Nonlinear Interactions in Ultrawide-Band WDM Transmission Systems," *IEEE Photon. Technol. Lett.*, vol. 11, no. 3, 1999, pp. 376-378.
- [12] F. Khaleghi, J. Li, M. Kavehrad, and H. Kim, "Increasing Repeater Span in High-speed Bidirectional WDM Transmission Systems Using a New Bidirectional EDFA Configuration," *IEEE Photon. Technol. Lett.*, vol. 8, no. 9, 1996, pp. 1252-1254.
- [13] J. Chung, S.Y. Kim, and C.J. Chae, "All-Optical Gain-Clamped EDFAs with Different Feedback Wavelengths for Use in Multiwavelength Optical Networks," *Electron. Lett.*, vol. 32, no. 23, 1996, pp. 2159-2161.
- [14] J. Massicot, C. Lebre, R. Wyatt, R. Kashyap, D. Williams, and A. Yu, "Low Noise, All-Optical Gain Controlled Er³⁺ Doped Fibre Amplifier Using Asymmetric Control Laser Cavity Design," *Electron. Lett.*, vol. 32, no. 9, 1996, pp. 816-817.
- [15] D.H. Richards, J.L. Jackel, and M.A. Ali, "A Theoretical Investigation of Dynamic All-Optical Automatic Gain Control in Multichannel EDFA's and EDFA Cascades," *IEEE J., Selected Topics in Quantum Electronics*, vol. 3, no. 4, 1997, pp. 1027-1036.
- [16] B. Landousies, T. Georges, E. Delevaque, R. Lebre, and M. Monerie, "Low Power Transient in Multichannel Equalized and Stabilized Gain Amplifier Using Passive Gain Control," *Electron. Lett.*, vol. 32, no. 20, 1996, pp. 1912-1913.
- [17] C.H. Kim, S.B. Yoon, S.B. Lee, C.-H. Lee, and Y.C. Chung, "All-Optical Gain-Controlled Bidirectional Add-Drop Amplifier Using Fiber Bragg Gratings," *IEEE Photon. Technol. Lett.*, vol. 12, 2000, pp. 894-896.
- [18] G. Luo, J.L. Zyskind, J.A. Nagel, and Mohamed A. Ali, "Experimental and Theoretical Analysis of Relaxation-Oscillations and Spectral Hole Burning Effects in All-Optical Gain-Clamped EDFA's for WDM Networks," *IEEE J. Lightwave Technology*, vol. 16, no. 4, 1998, pp. 527-529.



Bo-Hun Choi is a Lecturer in the Division of Optical Communications and Electronic Engineering, Gwangju University. He was born in Busan, Korea, on Nov. 5, 1967. He received the BS and MS degrees in physics from Pusan National University, Busan, Korea, in 1992 and 1994. He worked as an Engineer in the Photonics Device Lab, Hyundai Electronics from 1994 to 1995. He worked as an Assistant Manager in the Optical Communications R&D Group, Samsung Electronics from 1996 to 1998. He received the PhD degree in engineering from Information and Communications University (ICU) in 2001. He has worked as a Research Fellow in the Photonics Research Lab (PRL), Dept. of Electrical & Electronic Engineering, The University of Melbourne, Victoria, Australia. In PRL, he was involved in developing optical communication systems, bidirectional amplifiers, and modulation formats for ultra high speed transmission. His current research interests are in optical fiber amplifiers, WDM optical transmission systems, and optical Internet.



Kyung-Jin Hong is a Lecturer in the Division of Optical Communications and Electronic Engineering, Gwangju University. He received the PhD degree in engineering from Chonnam National University in 1996. He has worked as a Research Fellow in the Inorganic Material Institute (IMI), Tsukuba, Japan. In IMI, he was involved in developing electrical devices. His current research interests are in fractal theory, thin film processing, and surface analysis.



Chang-Bong Kim received the BS degree in electronics from Korea University, Seoul, Korea, in 1983, the MS degree in electrical engineering from Florida Institute of Technology, Melbourne, FL, USA, in 1988, and the PhD degree in electrical engineering from Texas A&M University, College Station, TX, USA, in 1992. He joined Samsung Consumer Electronics, Suwon, Korea, in 1992. From 1992 to 1993, he was the Senior Researcher of the Audio Electronic Division, developing an optical pick-up for domestic products. His research interests are in optical fiber sensors, bi-directional optical amplifiers, and optical transmission systems. Currently he is a Professor in the Division of Information and Communication Engineering at Kongju National University. He is a Senior Member of IEEE.



Yong Hyub Won is a Professor in ICU, Korea. He received the BS degree from University of Ulsan in 1978, the MS degree from Seoul National University in 1981, and the PhD degree from Cornell University, USA, in 1990. He worked as a Technical Staff Member and a Research Team Leader in Electronics and Telecommunication Research Institute (ETRI) from 1981 to 1997. In ETRI, he was involved in developing optical communication systems, optical logical devices, polymeric optical waveguide devices, and optical switching. His recent work in ICU has focused on optical CDMA, and optical packet/burst switching systems and devices. He has authored more than 150 journal or conference papers, holds 80 pending or registered patents, and has written 2 book chapters. His current research interests include optical packet/burst switching systems and networks, photonic sensors, and sensor networks. He has served as a member of Technical Program Committee in various international conferences including ECOC, OECC, COIN, Optics East and APOC.