

Transmission of Traffic Information Using a Terrestrial Digital Multimedia Broadcasting System

Sammo Cho, Geon Kim, Youngho Jeong, Chunghyun Ahn, Soo In Lee, and Hyuckjae Lee

ABSTRACT—This letter introduces an efficient transmission of traffic information through a terrestrial digital multimedia broadcasting system, which is a multimedia and mobility empowered option of the European digital audio broadcasting system. By adapting Korean characteristic traffic information into the transport protocol expert group messages in the traffic information delivery, a highly efficient traffic information system was implemented and tested in Korea.

Keywords—T-DMB, TTI, TPEG

I. Introduction

The Eureka-147 digital audio broadcasting (DAB) standard made a significant forward step by choosing the terrestrial digital multimedia broadcasting (T-DMB) system as one of its multimedia broadcasting functionalities. T-DMB, which was commercialized in Korea, is a multimedia empowered function of DAB launched in the year 2005 [1]-[5]. Although it is certain that mobile TV service through T-DMB will be the first killer application in Korea, the other audio and multimedia data services that are described in the Eureka-147 specification will be the same as the DAB services in Europe. Therefore, the transport protocol expert group (TPEG) [6]-[11] application service, one of the well-known traffic and travel information (TTI) services for DAB, is also possible in a Korean T-DMB network.

This letter analyzes the results of the trial implementation of a TPEG-based traffic information service system in a Korean

T-DMB network. As depicted in Fig. 1, the development includes a TPEG encoder to encode real-time traffic information into the TTI database, an adaptation module for a connection with the governmental traffic information providers of Korea, a streaming server to provide encoded TPEG messages to the T-DMB ensemble multiplexer while being rate-controlled by a user-specified service data rate, and finally a software-based TPEG decoder on a Windows-based PDA connected to a DAB receiver so that the decoded traffic information data can be used in the navigation tool installed in the PDA, which has a GPS receiver module.

II. Preparation of Information for TPEG Messages

TPEG is a bearer and language-independent TTI service protocol that has a unidirectional and byte-oriented asynchronous framing structure. The TPEG specification comprises an XML version and its binary version. In general, the XML specification is used for Internet service and exchanges of TTI information between traffic centers, while the binary version is used for air transmission through bearers such as DAB/T-DMB and DVB. TPEG currently has two XML applications. One is for the information of a road traffic event message, or road traffic message (RTM) application, and the other is for public transport information (PTI) message application. Other applications such as parking information (PKI) and congestion and travel time (CTT) information are about to be standardized [6]-[11]. TPEG frames are transmitted through the transparent data channel (TDC) of the DAB/T-DMB signal. The implementation for this thesis used a stream mode of the TDC for the delivery of TPEG binary applications.

The TPEG-RTM application describes traffic events in road networks. In order to get this traffic information, we implemented an adaptation module, which maintains a

Manuscript received July 20, 2005; revised Apr. 06, 2006.

This work was supported in part by the Ministry of Information and Communication of Korea.

Sammo Cho (phone: + 82 42 860 6428, email: semo@etri.re.kr), Geon Kim (email: kingeon@etri.re.kr), Youngho Jeong (email: yhcheong@etri.re.kr), Chunghyun Ahn (email: hyun@etri.re.kr), Soo In Lee (email: silee@etri.re.kr) are with Digital Broadcasting Research Division, ETRI, Daejeon, Korea.

Hyuckjae Lee (email: hjlee@jcu.ac.kr) is with the School of Engineering, Information and Communications University, Daejeon, Korea.

connection with one of the governmental traffic information gathering and providing organizations and saves the information to a traffic event database. Since there may be some different structural and environmental situations in the use of traffic information among many countries, including Korea, there may be different ways of using the values of the parameters in the TPEG message set. In this system, we tried to transmit link-speed information, which is very popular and therefore necessary in Korean navigation systems, through TPEG-RTM to show the specific traffic conditions of the specific links to users. For linkage with the road links in digital maps, we used a location referencing (Loc) message. For the transmission of a PTI application service, there needed to be a database containing public transportation schedules, which can be combined with real-time transportation information later by the service provider. Although it does not cover all the public transportation databases, we gathered some of the time tables of the public transportation networks around the Daejeon area of South Korea, and implemented a public transportation information database in the PTI message author software.

The basic forms of service and network information are implemented for the test stream. For the locations of each RTM and PTI event, TPEG-Loc is used with WGS84 (World Geodetic System, 1984) coordinates. This location information is very useful to show the specific location of an accident or event on a digital map in a navigational system.

III. T-DMB-Based TPEG Service Structure

1. T-DMB-Based TPEG Traffic Information Server

Figure 1 shows a TPEG information server providing TPEG-encoded messages to the T-DMB broadcasting system. The traffic information provider mostly provides the link-speed information of the vehicle on each of the road links in a Korean digital road map by gathering and processing data that are coming from the sensors and probe cars around the city. The adaptation module gets the traffic information data from the information provider through a dedicated Ethernet connection and filters out unnecessary information. After the adaptation, the data is being recorded as a TTI database. Reading the data from the TTI database, the TPEG encoder puts the data into the TPEG message frame according to the binary TPEG message structure and writes the message as a file in binary format. The stream server reads this file and provides the data to the T-DMB ensemble multiplexer or data inserter of the transmission system. Both of them are set for TDC use. Here, the traffic and travel information service data rate is being controlled by the streamer. This is done by using the binary file, which works as a buffer, between the TPEG encoder and streamer inside the

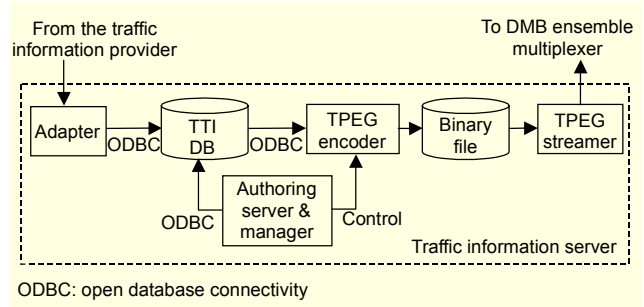

Fig. 1. The TPEG traffic information server.

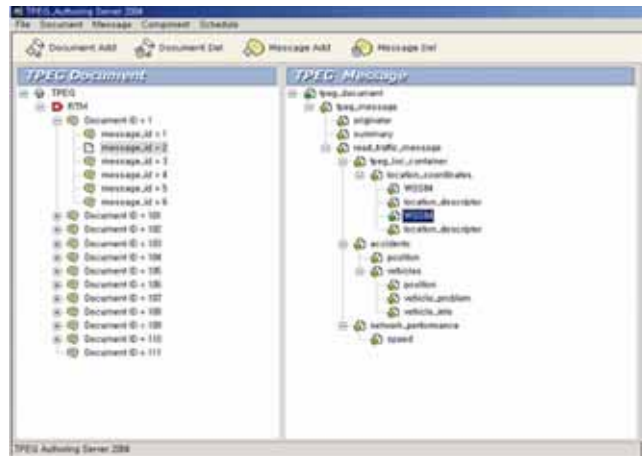

Fig. 2. TPEG authoring server for T-DMB.

system. As shown in Fig. 2, the TPEG authoring server has a user interface to control and monitor all the functionality of the system. It enables the user to access the database and modify, delete, and sometimes manually add a new urgent message.

2. T-DMB Receiver and TPEG Decoder

If the T-DMB signal is received by the receiver and the fast information channel of the DAB/T-DMB ensemble says that it contains the TPEG application service in the TDC, the data stream is provided to the TPEG decoder. Figure 3 shows the decoding structure of the received TPEG message. The TTI data in the T-DMB signal is decoded by the T-DMB receiver module and is parsed and decoded at the TPEG decoder before going into the navigation application.

In the implementation of the receiver, a general DAB/T-DMB data receiver with USB interface is used for the T-DMB signal reception. By using this receiver, all the data in the T-DMB signal can be decoded and provided to the PDA on which a navigation application with digital maps and GPS connection capability, as well as TPEG decoding module, is installed. Figure 4 shows a navigation example with a TPEG message from the TPEG decoder and a digital map installed in the receiver. Figures 4(a) and 4(b) show simple RTM and PTI message decoding

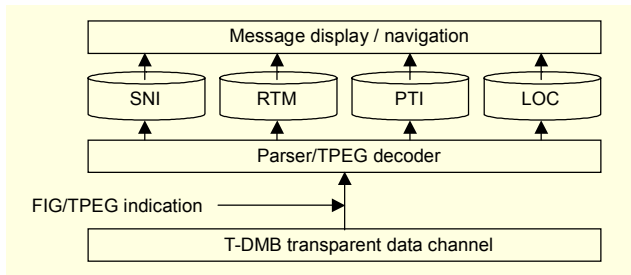

Fig. 3. The TPEG message decoding structure.



Fig. 4. Simple TPEG message and navigation.

results. The decoded event contents are displayed with appropriate icons in time order on the display of a navigator. A TPEG message service combined with navigational tools is shown in Fig. 4(c). If the RTM and PTI messages as in Figs. 4(a) and 4(b) have the specific location information in the LOC part, the icon will appear on the map of the navigator in order to show if the event will give any influence on a user's way to his or her destination. Sometimes, automatic re-routing is necessary when the event seriously intrudes the pre-searched navigation routes. In this case, link-speed information for each link is useful for re-routing. The information also can be used to notify the users of the severity of the traffic condition of each link with several colors.

A test of the implemented system was done using a receiver and navigator as shown in Fig. 4 in an out-door reception field (city) of Daejeon, South Korea. We transmitted the TPEG message contained T-DMB signal with a 40 W power transmitter covering the test field, while the TPEG information server converted the traffic information data from the traffic information provider. In 5 km of coverage, and 96 kbps of TTI service in the T-DMB ensemble, both the T-DMB-based TTI service provider and the TPEG message based navigation system worked well in most of the area.

IV. Analysis and Conclusion

This letter introduced the results of a trial implementation for TPEG service in a Korean T-DMB network. We implemented a TPEG authoring server, adaptation module, and stream server to automatically make a TPEG message from the data coming

from the information provider, and to provide the encoded TPEG messages to the T-DMB ensemble multiplexer with the user specified data rate. We also implemented a software TPEG decoder in a PDA, which is connected to the T-DMB receiver, to verify that the transmitted traffic information could be successfully used in the navigation system. Compared to the recommended general data rate of around 10 kbps [1], we used a higher data rate in this implementation because of the real-time link speed information (over 90%) and other experimental signals. The test result shows that the system can be easily used for a new traffic information service in a Korean mobile communication and broadcasting environment while satisfying the European TPEG specification. It is certain that any other TPEG application like PKI and CTT is possible as long as it has a TPEG frame structure. Furthermore, the implemented system can be used as a platform for new applications that will be added to the TPEG standard in the future. For a higher data rate multimedia TTI service in the near future, the necessities of more efficient management of the data service remain for future works.

References

- [1] ETSI EN 300 401 Ver. 1.3.3, *Radio Broadcasting Systems; Digital Audio Broadcasting (DAB) to Mobile, Portable and Fixed Receivers*, May 2001.
- [2] ETSI EN 102 428 Ver. 1.1.1, *Digital Audio Broadcasting (DAB); DMB Video Service; User Application Specification*, June 2005.
- [3] M Tsavachidis, R Biehn, and H Keller, "DAB for a New Quality of Dynamic Traffic Information," *Proc. of Road Transport Information and Control*, 2000, pp. 37-40.
- [4] Byungjun Bae, et. al., "Design and Implementation of the Ensemble Remultiplexer for DMB Service Based on Eureka-147," *ETRI J.*, vol.26, no.4, Aug. 2004, pp. 367-370.
- [5] Wolfgang Hoeg and Thomas Lauterbach, *Digital Audio Broadcasting Principles and Applications*, John Wiley & Sons, 2001.
- [6] EBU B/TPEG, *TPEG Specifications, Part 1 : Introduction, Numbering and Versions*, TPEG-INV/002, draft, Oct. 2002.
- [7] EBU B/TPEG, *TPEG Specifications, Part 2 : Syntax, Semantics and Framing Structure*, TPEG-SSF_3.0/002, draft, Oct. 2002.
- [8] EBU B/TPEG, *TPEG Specifications, Part 3 : Service and Network Information Application*, TPEG-SNI_3.0/002, draft, Oct. 2002.
- [9] EBU B/TPEG, *TPEG Specifications, Part 4 : Road Traffic Message Application*, TPEG-RTM_3.0/003, draft, Oct. 2002.
- [10] EBU B/TPEG, *TPEG Specifications, Part 5: Public Transport Information Application*, TPEG-PTI_3.0/001, draft, Dec. 2002.
- [11] EBU B/TPEG, *TPEG Specifications, Part 6: Location Referencing for Applications*, TPEG-Loc_3.0/001, draft, Oct. 2002.