

## FIGURE CAPTIONS

- Fig. 1 Geometry of fiber path on surface  $S(x, \theta)$ .
- Fig. 2 Configuration of the 3<sup>rd</sup> stage motor case.
- Fig. 3 Finite element mesh and boundary conditions.
- Fig. 4 The location of strain gages attached.
- Fig. 5 Schematic diagram of experimental setup.
- Fig. 6 Deformation shape and strain distribution in the fiber direction.(10 times magnified,  $P = 6.895$  MPa)
- Fig. 7 Deformation shape and strain distribution in the fiber direction with & without reinforcements.(10 times magnified,  $P = 6.895$  MPa)
- Fig. 8 Comparison of the strains between numerical and experimental results.
- Fig. 9 Transverse stress development of matrix cracked element with respect to internal pressure.
- Fig. 10 The location of first failure occurrence for each mode

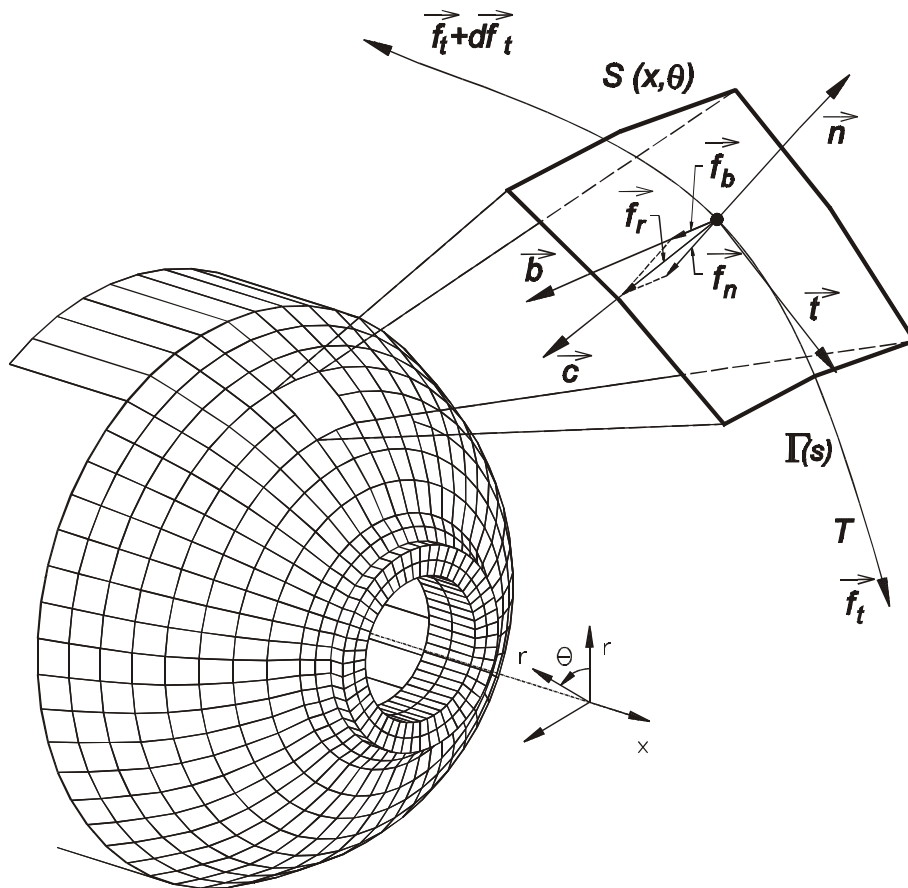

Fig. 1 Jae-Sung Park, Cheol-Ung Kim, Hyun-Kyu Kang, Chang-Sun Hong and Chun-Gon Kim

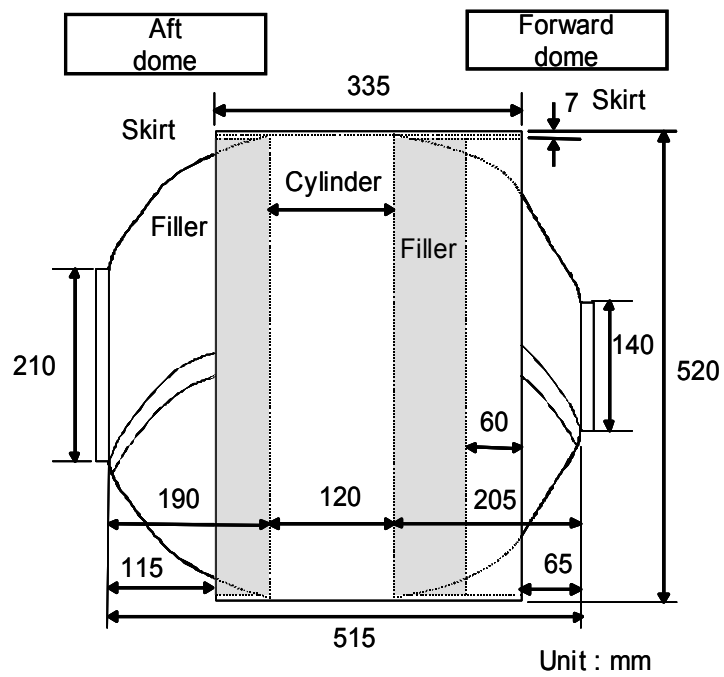
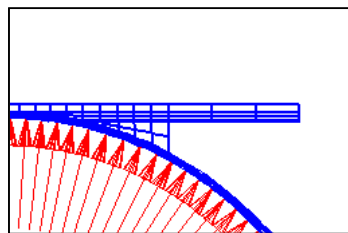
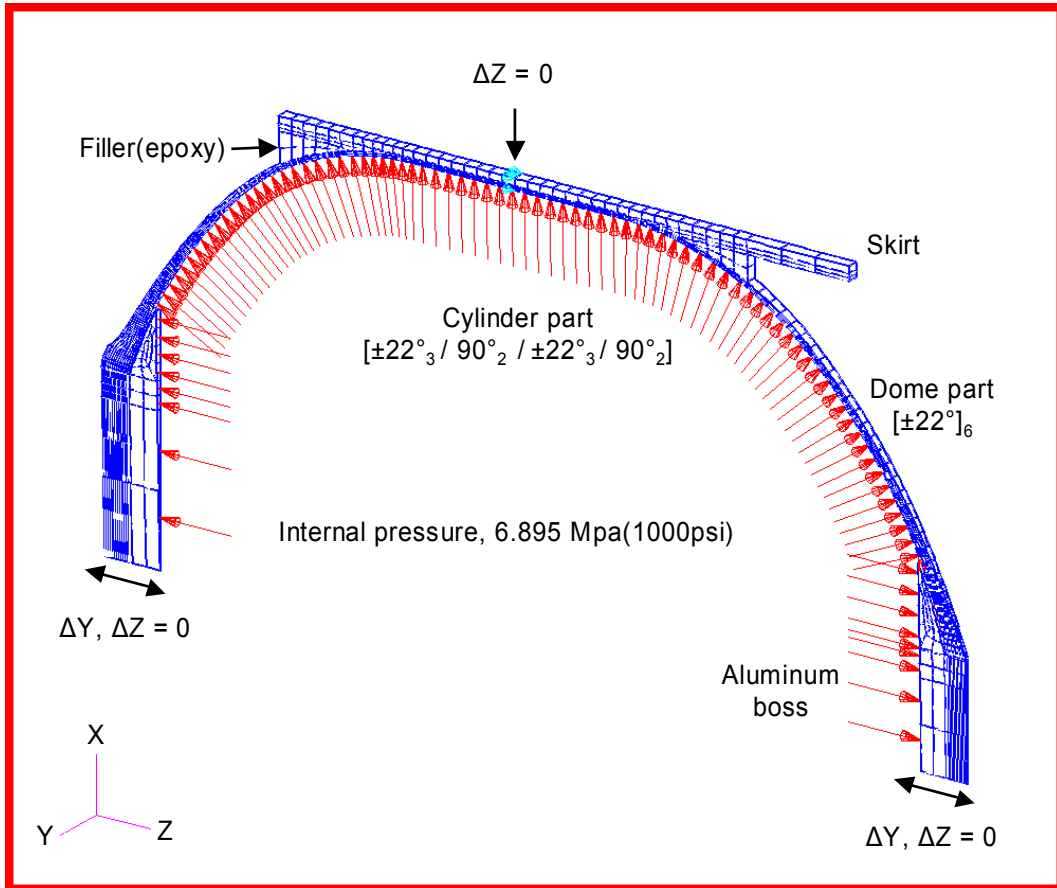

Fig. 2 Jae-Sung Park, Cheol-Ung Kim, Hyun-Kyu Kang, Chang-Sun Hong and Chun-Gon Kim



2<sup>nd</sup> skrit (upper)  
 $[90^\circ_2 / \pm 15^\circ_2 / 90^\circ_2 / \pm 15^\circ_2 / 90^\circ_6]$   
 1<sup>st</sup> skrit (lower)  
 $[\pm 30^\circ_4 / 90^\circ_2 / \pm 30^\circ_4 / 90^\circ_2]$

Fig. 3 Jae-Sung Park, Cheol-Ung Kim, Hyun-Kyu Kang, Chang-Sun Hong and Chun-Gon Kim



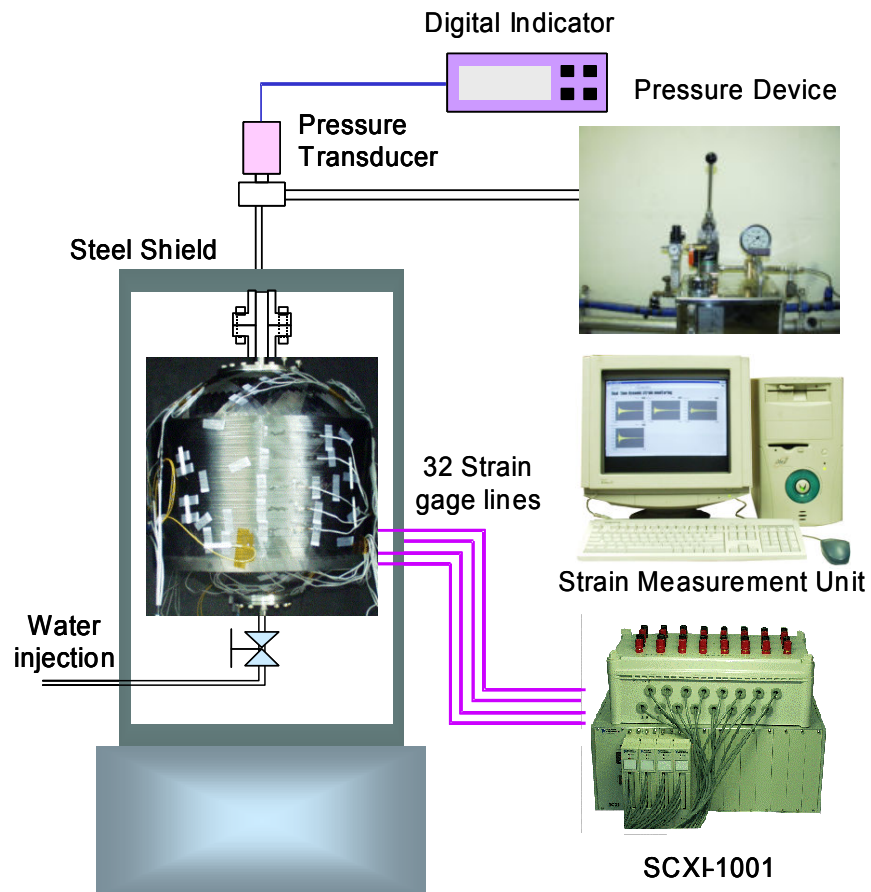

Fig. 5 Jae-Sung Park, Cheol-Ung Kim, Hyun-Kyu Kang, Chang-Sun Hong and Chun-Gon Kim

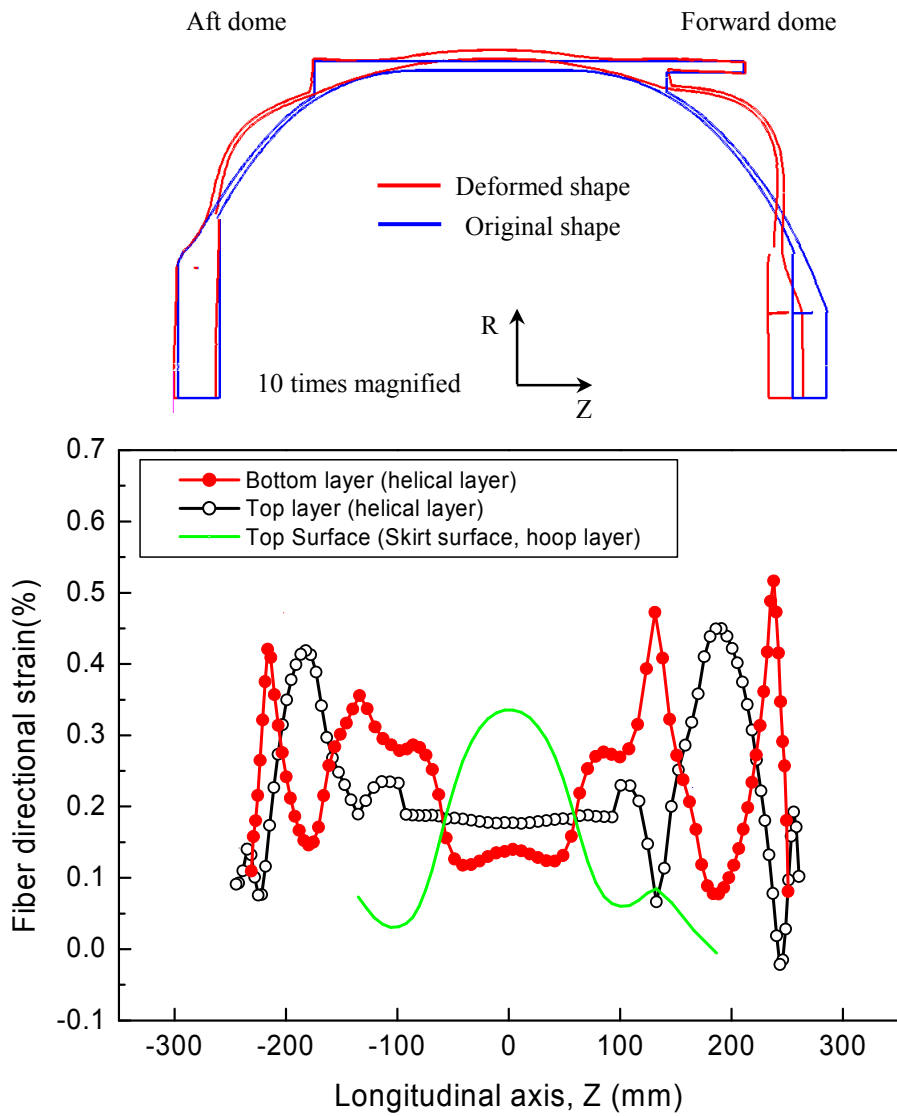

Fig. 6 Jae-Sung Park, Cheol-Ung Kim, Hyun-Kyu Kang, Chang-Sun Hong and Chun-Gon Kim

Without reinforcements

With reinforcement in the dome part

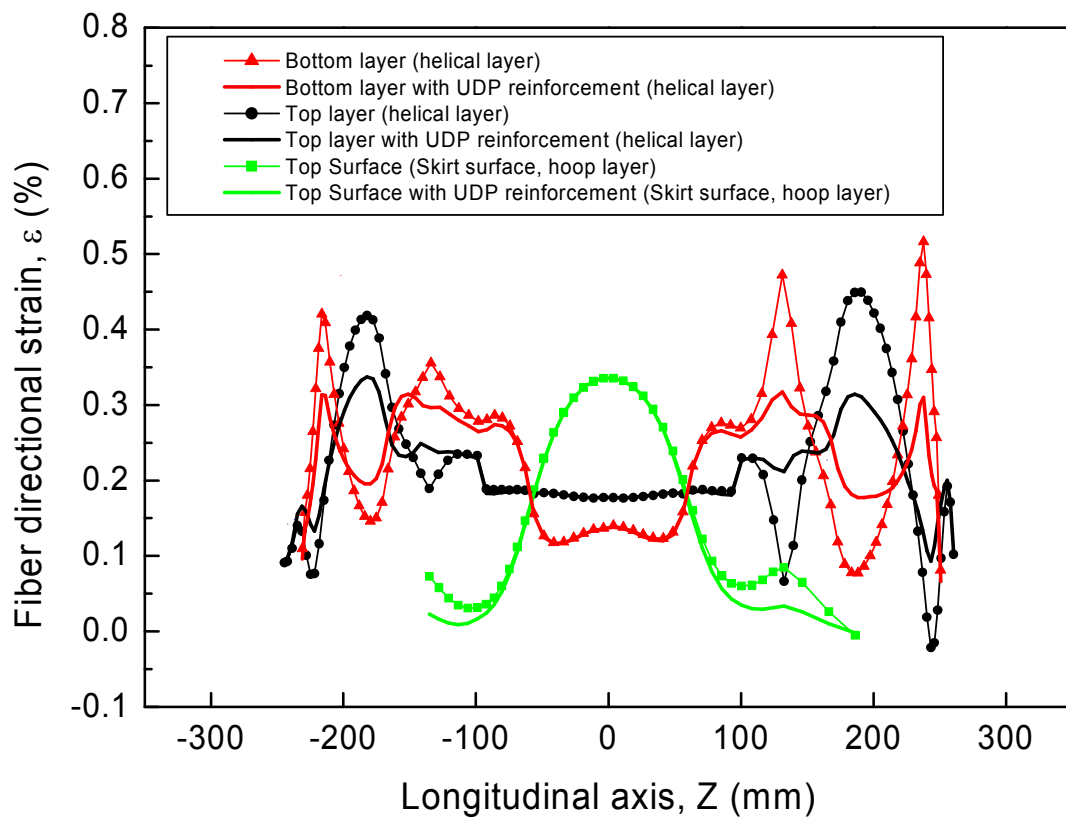
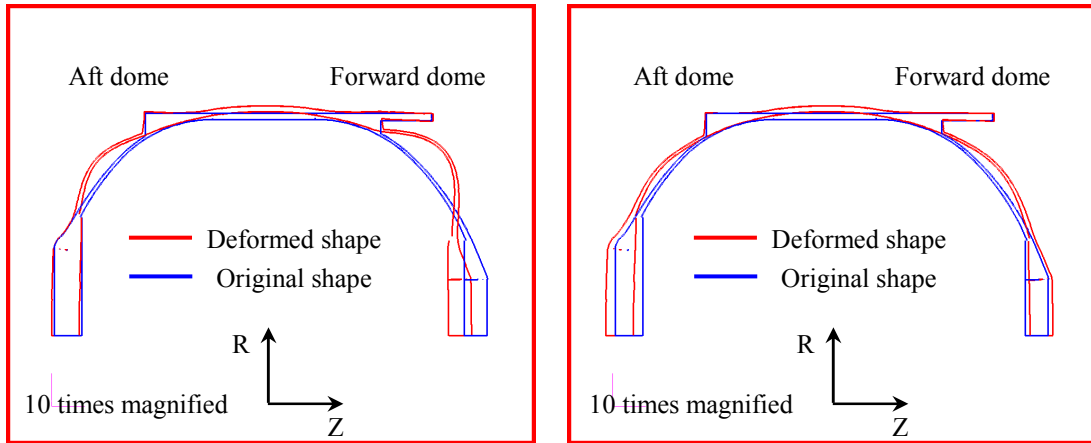

Fig. 7 Jae-Sung Park, Cheol-Ung Kim, Hyun-Kyu Kang, Chang-Sun Hong and Chun-Gon Kim



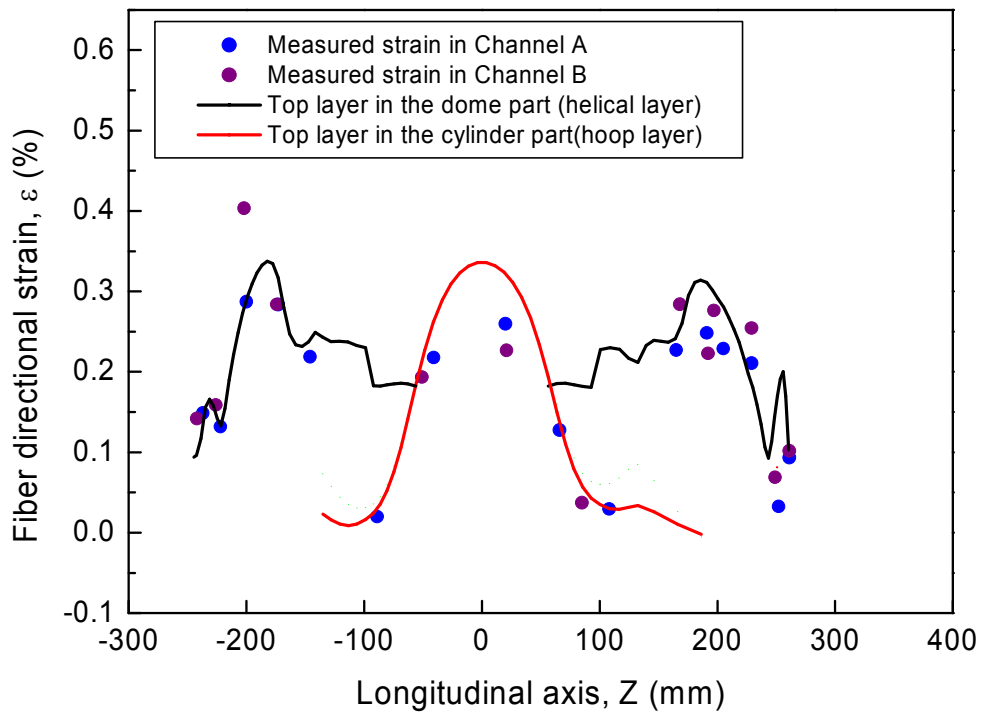
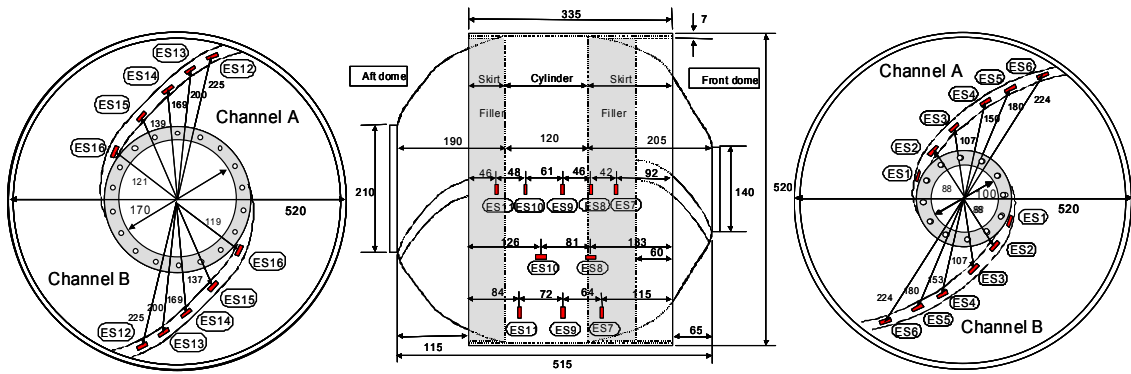

Fig. 8 Jae-Sung Park, Cheol-Ung Kim, Hyun-Kyu Kang, Chang-Sun Hong and Chun-Gon Kim

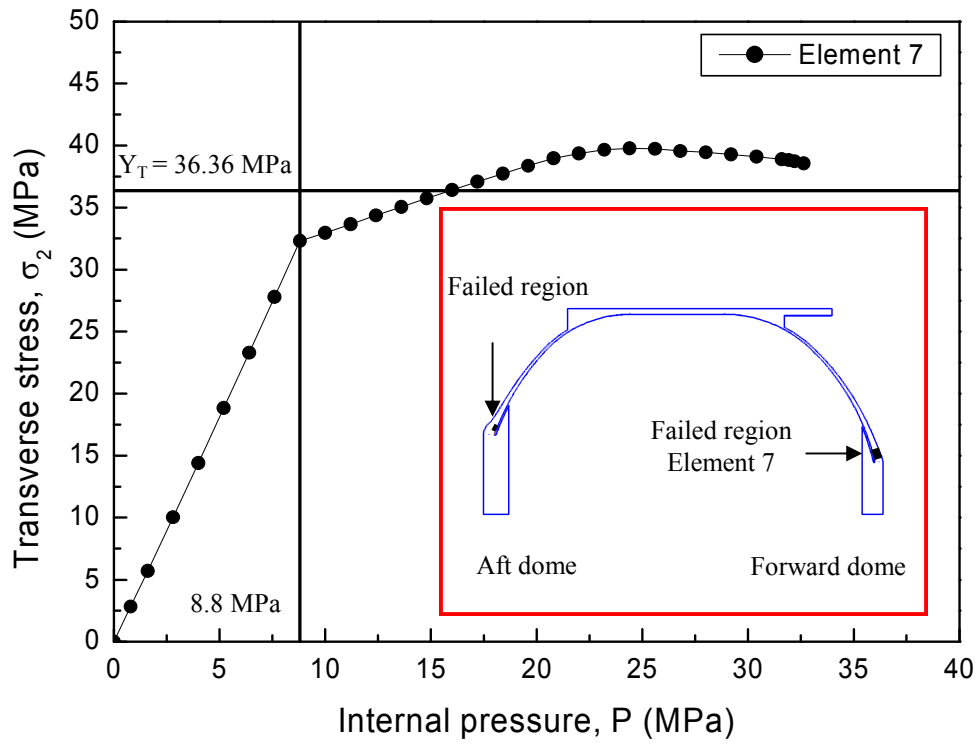

Fig. 9 Jae-Sung Park, Cheol-Ung Kim, Hyun-Kyu Kang, Chang-Sun Hong and Chun-Gon Kim

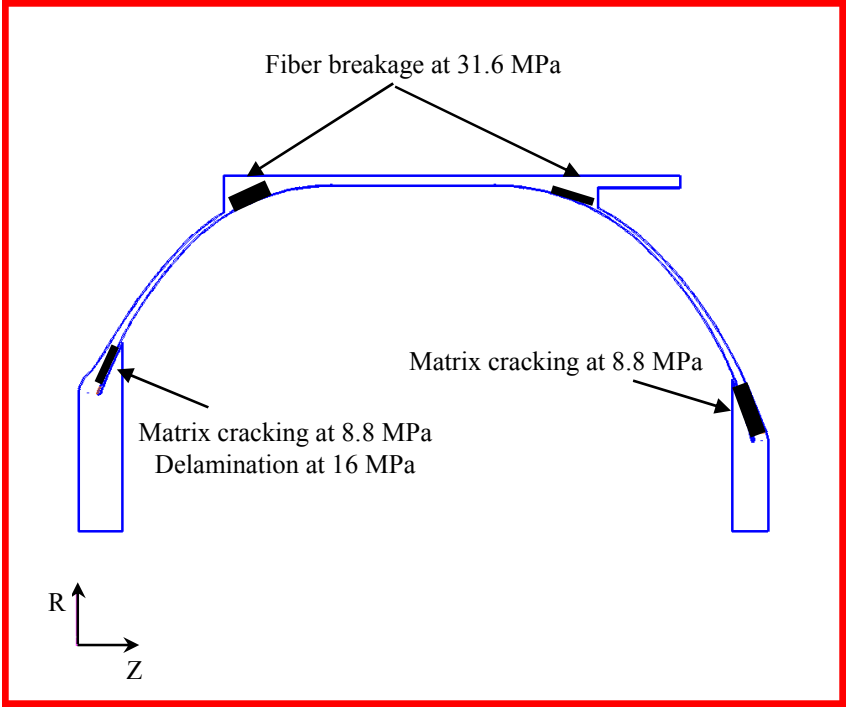

Fig. 10 Jae-Sung Park, Cheol-Ung Kim, Hyun-Kyu Kang, Chang-Sun Hong and Chun-Gon Kim