

Fast Handover Based on Mobile IPv6 for Wireless LAN

Hyon G. Kang and Chae Y. Lee

Department of Industrial Engineering, KAIST,

373-1 Kusung-dong, Taejon 305-701, Korea

chae@kaist.ac.kr

Abstract: Mobile networking technology is progressing to support the requirements of today's new class of Internet users who roam about with sophisticated mobile computers and digital wireless data communication devices. Host mobility requires change in the routing protocol so that packets for a moving host can be delivered to their correct destination. Mobile IP (Internet Protocol) allows a mobile node to send and receive packets with its home IP address, regardless of the IP address of its current point of attachment in the Internet. Since Mobile IP induces the handover latency due to mobility management operations, fast handover algorithms have been studied to reduce the latency.

Normal and fast handover procedures for Wireless LAN are introduced and compared each other. We propose an overall procedure that manages the layer 2 (L2: link layer) and layer 3 (L3: network layer) handovers simultaneously. Two types of the L2 triggers in Wireless LAN system are introduced: pre-handover-trigger and link-state-trigger. Two criteria are defined to analyze the performance of the triggers: handover timeliness and handover accuracy. The fast handover reduces route reestablishment delay by 80 ~ 90 % and total handover delay by 20 ~ 25 % compared to the normal handover.

Key words: Fast handover; Handover triggers; Mobile IP; Wireless LAN

1. Introduction

The IPv4 is becoming obsolete because of its limited address space and lack of security features. IPv6 has been standardized to carry multiple applications in next generation IP network. Mobile IPv6 allows a Mobile Node (MN) to send and receive packets with its home address regardless of the IP address of its current point of attachment in the Internet. It also takes advantage of the IPv6 features to offer seamless handover. Effective L3 handover algorithms that significantly reduce the amount of service disruption due to the handover have been studied in the IETF Mobile IP working group [1].

In Mobile IPv6 a smooth L3 handover algorithm with buffering packets and transmitting through uni-directional tunnel is proposed [2]. However, no packet is transmitted from the MN to the Correspondent Node (CN) before the binding updates to the Home Agent (HA) and the CN are completed. Because this handover latency prevents serving the real-time delay sensitive traffics, Fast Handover using the L2 information is investigated to minimize the latency [3]. The information allows the MN and Access Routers (ARs) to prepare handover by establishing bi-directional edge tunnel prior to the L2 handover. The information is the critical factor in achieving good performance for the handover procedure.

There are two types of triggers based on the L2 information [4]. The first type is link-state-trigger: Link Up (L2-LU) and Link Down (L2-LD). Since these triggers are generated as the result of L2 handover, L2 system is usually guaranteed to supply link-state-trigger. The second type is pre-handover-trigger: Source Trigger (L2-ST), Target Trigger (L2-TT), and Mobile Trigger (L2-MT). For the purpose of pre-handover-trigger these must be generated sufficiently before L2 handover. However, pre-handover-triggers cannot be guaranteed in normal system due to L2 system performance. For implementation of fast handover pre-handover-triggers need to be investigated for Wireless LAN (WLAN) systems.

IEEE 802.11 based Wireless Local Area Network (WLAN) has experienced rapid growth and deployment in recent years. WLAN provides convenient network connectivity with high speed up to 11 Mbps. In WLAN MN connects to an Access Point (AP) at L2. The MN is authenticated by an AAA

(Authentication, Authorization, and Accounting) server and associated with one AP. Then MN is connected to the Internet via AP, AR, and Gateway as in Figure 1. When MN moves to another AP, a pre-authentication and reassociation is established with the AP. It is called L2 handover in WLAN.

In WLAN there is no definite L2 handover protocol yet [5]. However, Inter Access Point Protocol (IAPP) service is proposed for L2 handover in IEEE 802.11f [6]. We assume that MN travels around mobile network given in Figure 1. Then L2 and L3 handovers have to be processed to support mobility of the MN. In this paper we introduce an overall procedure that manages the two layer handovers simultaneously. We propose normal and fast handover procedures in WLAN system.

Several problems for the handover in WLAN are suggested personally in the IETF Mobile IP working group. Goswami [7] explains a way to perform simultaneous Mobile IPv4 handover and WLAN AP Association/Reassociation. In the work Mobile IPv4 registration messages are carried as information elements in WLAN frames. L2 data frame format is proposed. It considers only intra-agent handover in

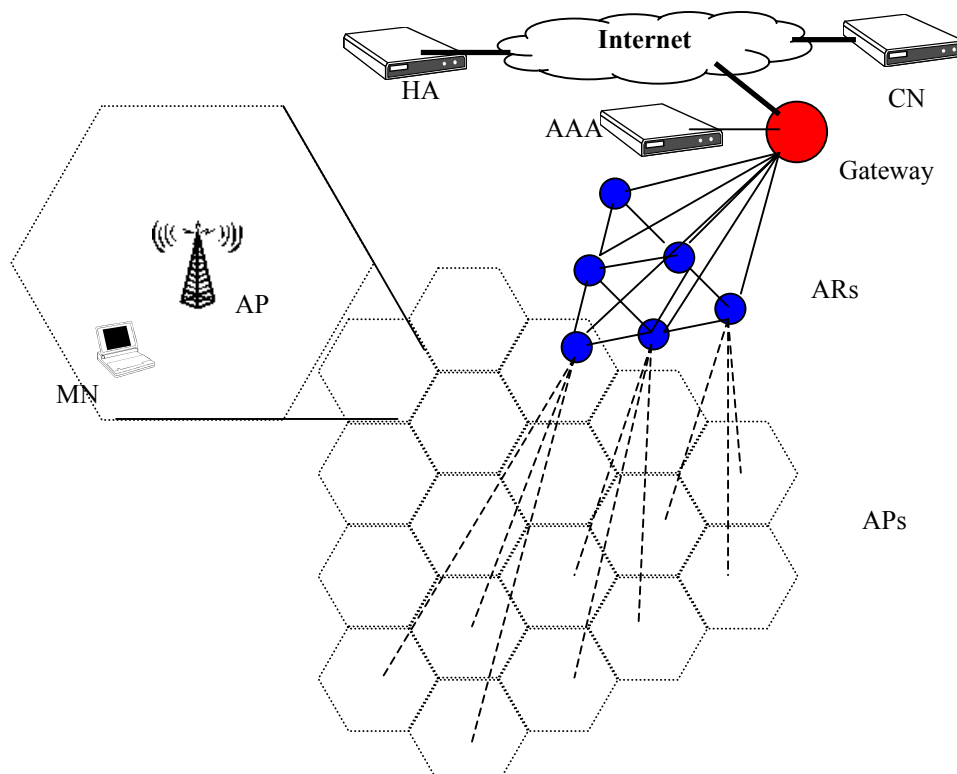

Figure 1 WLAN System

Mobile IPv4 and has implementation issues. McCann [8] describes how a Mobile IPv6 Fast Handover can be implemented in L2 that conforms to WLAN specifications. The focus is on the deployment of architectures for Mobile IPv6 in WLAN and L3 handover.

In this paper, the design and implementation problems of L3 handover in L2 wireless systems are considered. Efficient and fast handover algorithm is established to connect MN to AR. Two problems are solved:

1. How to allow MN to send packets as soon as it detects a new link
2. How to deliver packets to MN as soon as its presence is detected

In normal handover, MN continuously measures the signal strength of the current wireless link and decides handover from the previous AR (PAR) to the new AR (NAR). It probes target AP of the handover before current link is disconnected. After disconnection it reassociates to AP through WLAN IAPP procedures. The MN requests registration to NAR after it receives advertisement message from NAR. Then NAR allocates a Care-of-Address (CoA) and updates the binding at its HA/CN through Mobile IPv6 procedures. Finally, MN communicates with HA/CN via NAR.

Since the above normal handover procedure is not applicable in real-time, we propose a fast handover procedure for WLAN which considers L2 and L3 handovers simultaneously. For the fast handover procedure we define triggers and compare the triggers in view of handover timeliness and handover accuracy. Proposed handover procedures are analyzed in Mobile IPv6 network. The effects of triggers are studied based on a proper mobility model. Simulation is performed to show that the proposed handover procedure is effective to be implemented in real environment. The fast handover procedure reduces route reestablishment delay efficiently. The procedure well supports delay and throughput sensitive traffics [9, 10] with acceptable quality of service (QoS) in WLAN systems.

The remainder of this paper is organized as follows. In Section 2, we discuss fast handover procedure and triggers in Mobile IPv6 network. Normal and fast handover procedures in WLAN are discussed in

Section 3. Definitions of triggers in WLAN and implementation issues are discussed in Section 4. Computational experiments are performed in Section 5. Finally we conclude our study in Section 6.

2. Fast Handover and Triggers

Mobile IP supports MN to maintain connectivity to the Internet during its handover from one AR to another. During handover operation Mobile IP involves movement detection, IP address configuration, and location update. This combined handover latency may preclude MN from real-time and throughput sensitive applications [11]. Figure 2 shows a normal handover procedure in Mobile IPv6 [2]. When MN moves from PAR to NAR, handover occurs. When packets are lost during the handover, they are retransmitted by higher-level protocols. If L2 connection between MN and previous AP (PAP) fails, then L3 connection between MN and PAR also fails. L2 and L3 handovers are started at this point. After L2 handover, MN receives *Router Advertisement (RA)* message or sends *Router Solicitation (RS)* message to NAR via new AP (NAP). Then MN requests new CoA to NAR and registers to HA. After authentication from HA, L3 handover is completed. Since router discovery delay is closely related to L2 system, an efficient L3 handover algorithm is necessary to reduce delay due to the route reestablishment.

2.1. Fast Handover Procedure in Mobile IPv6

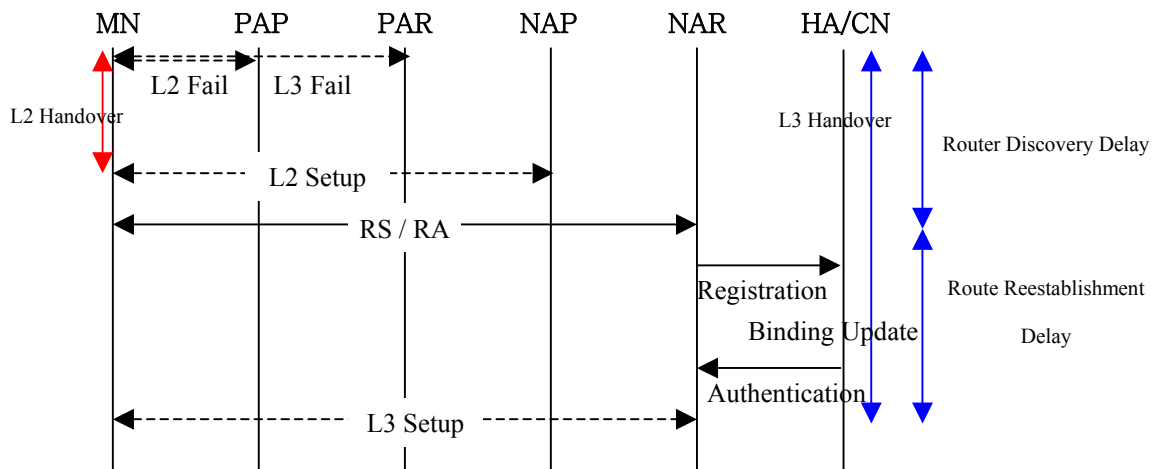

Figure 2 Overall Handover Procedure

Fast Handover is a protocol to reduce combined latency due to the Mobile IPv6 handover operation [3]. Important issues that have to be solved for the Fast Handover includes how to allow MN to send packets as soon as it detects new link, and how to deliver packets to MN as soon as its presence is detected by NAR. The solution is to keep the MN's previous CoA (PCoA) until it establishes L2 connection to its NAR. This also allows MN fast establishment of new CoA (NCoA). Fast Handover does not depend on specific L2 features for improved performance. Moreover, there is no special requirement for MN with respect to its standard Mobile IP operations [3].

The main operation of the Fast Handover involves setting up a routing path between old and new ARs to enable MN to send and receive IP packets. This tunnel establishment could be triggered either by MN or by network. Once the tunnel is established, packet forwarding through the tunnel to MN begins when PAR receives *Fast Binding Update (FBU)* message from MN. Thus, three phases are related in the Fast Handover operation: handover initiation, tunnel establishment, and packet forwarding [3]. The overview of Fast Handover procedure is illustrated in Figure 3. The figure shows handover initiation and tunnel establishment before L2 handover (Disconnection in the figure) and packet forwarding phase after L2 handover (Connection in the figure). Detailed explanation of the procedure is as follows:

Typically, it is MN that starts handover by sending *Router Solicitation for a Proxy (RtSolPr)* message to its PAR. *RtSolPr* message includes L2 identifier of MN's prospective attachment point, NAR. In response to *RtSolPr* message PAR sends *Proxy Router Advertisement (PrRtAdv)* message, which provides parameters necessary for MN to send packets to NAR and network prefix information of NAR. In the stateless address autoconfiguration, PAR may configure NCoA for MN and inform MN about NCoA which is not verified yet.

In the network-initiated handover, *RtSolPr* message is omitted. PAR then sends *Handover Initiate (HI)* message to NAR. *HI* message has two purposes. First, it initiates establishing a bi-directional tunnel between two ARs so that MN can use PCoA. Second, it verifies if NCoA can be used on NAR's link either supplied by PAR in stateless address autoconfiguration or determined by NAR in stateful address autoconfiguration. In response to *HI* message, NAR sets up a host route for MN's PCoA and responds with *Handover Acknowledge (HACK)* message. Consequently, *HI* and *HACK* messages construct tunnel and verify NCoA. In stateful mode *PrRtAdv* message should be sent to MN when PAR received *HACK* message.

When MN receives *PrRtAdv* message, it sends *Fast Binding Update (FBU)* to PAR. MN may also send *FBU* after attaching to the NAR. This *FBU* message associates the MN's PCoA with NAR's L3 IP address so that packets arriving at PAR can be tunneled to NAR.

After receiving *FBU* message, PAR sends *Fast Binding Acknowledgment (FBACK)* message to MN. *FBACK* message confirms whether NCoA could be used. When attached to the NAR, MN sends *RS* message with *Fast Neighbor Advertisement (FNA)* option. *FNA* includes MN's PCoA and link-layer addresses and announces MN's presence to NAR. When the *FBACK* has not been received, *FNA* confirms

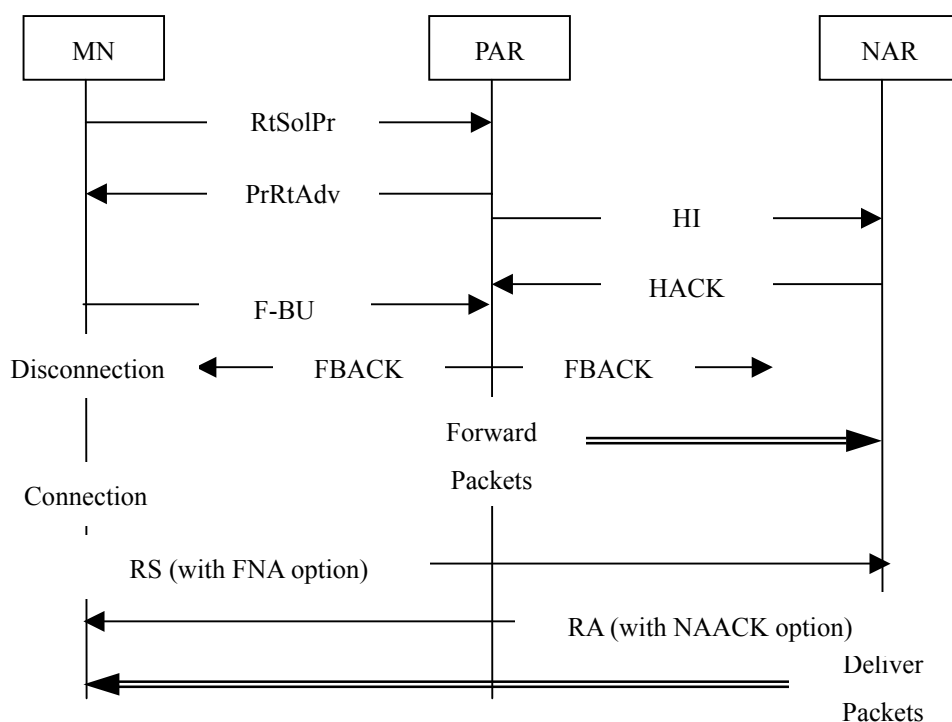

NCoA. As a response, NAR sends *RA* with *Neighbor Advertisement Acknowledge (NAACK)* option that indicates whether the use of NCoA is acceptable.

CN rejects packets sent with NCoA until a valid binding cache entry is established. Hence, it is desirable to use an address that exists in CN's binding cache until new address is updated. Thus, combined use of PCoA at CN and PAR and the NCoA at PAR and NAR is likely to enhance the handoff performance [3].

2.2. L2 Triggers for Fast Handover

As mentioned in Section 2.1 the Fast Handover procedure is designed to reduce handover latency of L3. It depends on obtaining timely information from L2 protocol about the progress of L2 handover. In this section we introduce normal L2 triggers that provide information in the procedure of L2 handover. L2 trigger is not associated with any specific L2 system but rather is based on L2 information that is available from a wide variety of radio link protocols. L2 trigger is an abstraction of a notification from L2 that certain event has happened or is about to happen. The trigger may be implemented in a variety of ways [4].

L2 trigger involves three types of information: event that causes L2 trigger to fire, IP entity that receives the trigger, and parameters delivered with the trigger. Based on L2 and L3 handover processes five L2 triggers are summarized in [4].

Two types of triggers are considered based on L2 information. The first type is link-state-trigger: Link Up (L2-LU) and Link Down (L2-LD). Since these triggers are generated as a result of L2 handover, L2 system is usually guaranteed to supply link-state-trigger. The second type is pre-handover-trigger: Source Trigger (L2-ST), Target Trigger (L2-TT), and Mobile Trigger (L2-MT). For the purpose of pre-handover-trigger these triggers must be generated sufficiently before L2 handover.

2.3. Implementation Problems in Fast Handover

The Fast Handover procedure in Figure 3 has some implementation problems because it is fully dependent on L2 trigger information. The handover timeliness and handover accuracy of L2 trigger significantly affects performance of the Fast Handover procedure. The untimely L2 information may degrades advantage of the Fast Handover compared to the normal handover procedure. Furthermore, incorrect information may waste system resources.

NCoA configuration process is triggered by one of pre-handover-triggers: L2-ST, L2-TT, and L2-MT. These triggers should be fired sufficiently earlier than L2 handover. In the Fast Handover there are two types of NCoA configuration: stateless and stateful address autoconfiguration. In the stateless mode, MN or PAR configures NCoA and requests validation of address to NAR with *HI* message. Then, NAR responses *HACK* message to PAR. In the stateful mode, NAR configures NCoA within its address pool when it receives *HI* message. Since longer process is required in the stateful mode, timeliness of L2 trigger information becomes an important factor. Additionally, if NCoA configured by stateless process is invalid in the domain of NAR, the time spent by NCoA configuration becomes long. Thus, it is very important that L2 triggers are fired in appropriate time.

The handover timeliness of L2 trigger directly affects handover latency. Fast binding update process is triggered by link-state-triggers: L2-LD and L2-LU. These triggers should be fired at the exact time of start and finish of L2 handover. Too early delivery of *FBU* or *FBACK* messages may break the link between PAR and MN. Then MN cannot communicate with CN though it is in a reliable domain of PAR. Too late delivery also prevents the use of valid NCoA. Then MN should request NAR to build a new tunnel with PCoA. It brings unnecessary load to NAR and delays L3 handover.

3. Fast Handover for WLAN

IEEE 802.11 based WLANs have experienced rapid growth and deployment in recent years. WLAN

provides convenient network connectivity with high speed up to 11 Mbps. In WLAN MN connects to AP at link-layer. An MN is authenticated and associated with one AP. Then the MN is connected to the Internet via AP, AR, and Gateway. When the MN moves to another AP, pre-authentication and reassociation are established with the second AP [5, 6].

3.1. Normal Handover Procedure for WLAN

To support handover WLAN IAPP service is proposed for L2 handover in IEEE 802.11f. By assuming that MN travels around the mobile network given in Figure 1, L2 and L3 handovers have to be processed to support the mobility of MN. In this section we introduce a detailed procedure that manages L2 and L3 handovers simultaneously. The process of normal handover for the WLAN is explained as follows with Figure 4.

- (1) Currently, MN connects to PAR via PAP. PAR assists connection between MN and HA/CN.
- (2) PAP broadcasts beacon message to inform MN about the domain information periodically. This signal is broadcasted in the constant power level. MN's MAC layer measures power strength of the signal continuously and reports result to PAP's MAC layer.
- (3) When the measured power strength becomes less than a threshold T_1 , MN and PAP prepare the handover. In this phase the handover is classified into two types: Mobile Initiated Handover and Network Initiated Handover. Also, there are two kinds of AP scanning method: Active Scan and Passive Scan. As the name suggest, in Active Scan, apart from listening to beacon messages which is in Passive Scan, MN sends additional probe broadcast packet and receives responses from APs. Thus MN actively probes APs.
- (4) We assume that the WLAN system supports Mobile Initiated Handover and Active Scan method. Then, MN sends *Probe_Request* message with L2 broadcast address to all neighbor APs when the signal strength from PAP becomes less than T_1 .

- (5) All APs that received the *Probe_Request* response to MN with *Probe_Response* message. The response message provides information about the environment of each AP and received signal strength of the request message. Then MN generates an alternative set of new APs that satisfy the received signal strength larger than a threshold T_2 . MN then selects an AP as the target when the AP belongs to the alternative set during a dwell time threshold T_3 . That is, MN decides the target AP based on signal strength and dwell time thresholds. Thus, proper thresholds, T_2 and T_3 play an important role in the Fast Handover. We assume NAP is the selected AP.
- (6) MN and NAP synchronize their clock by sending and receiving *Probe_Request* and *Probe_Response* messages. Due to disconnection between MN and PAR, L2 and L3 handovers start. Note that, L3 handover starts after the MN recognizes NAP. However, L3 handover delay is counted from this point. MN sends *Reassociation_Request* message to NAP.
- (7) NAP receives MN's Basic Service Set (BSS) information and sends the information to AAA server with *Access_Request* message. Then AAA server authenticates validity of the MN.

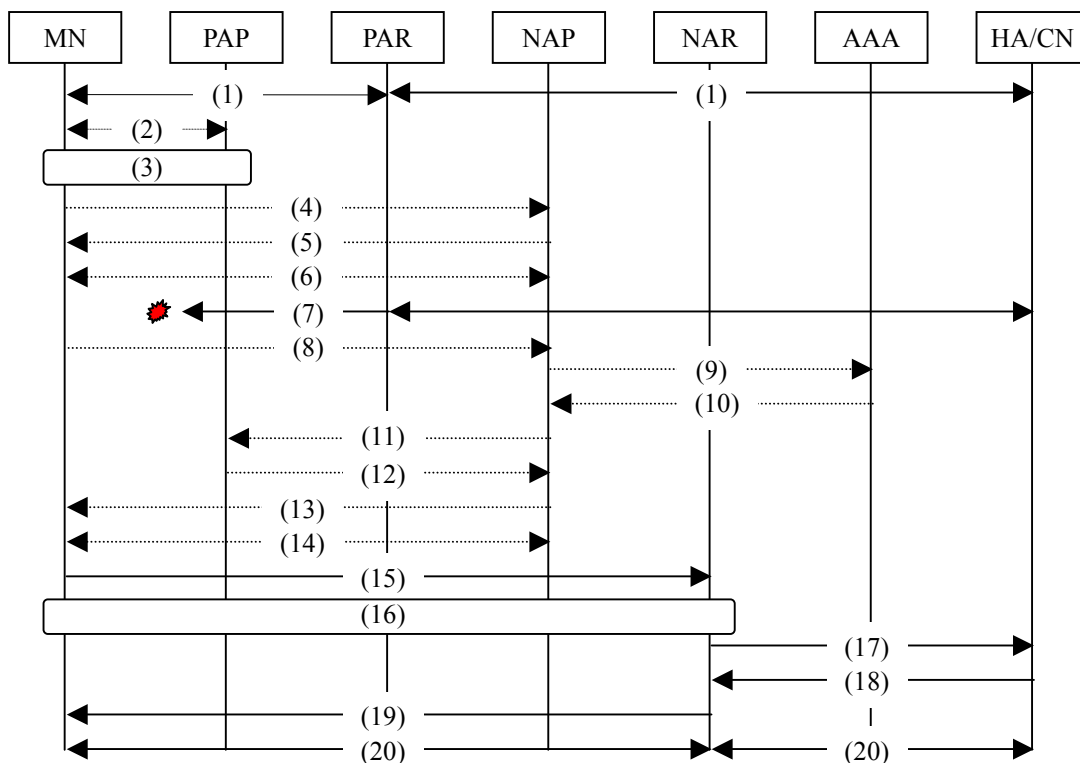

Figure 4 L2 and L3 Handovers for WLAN

- (8) If MN is a valid subscriber of Extended Service Set (ESS), AAA server sends the information about MN's PAP to NAP by *Access_Accept* message. If MN is invalid or is not a subscriber of the ESS, AAA server sends a reject message, *Access_Reject*. In the latter, MN starts a new association process. We assume that MN is valid.
- (9) In WLAN IAPP [6] MN may have only a single association at any given time. Thus NAP sends *Move_Request* message to PAP to remove the association between MN and PAP.
- (10) The PAP deletes previous association and responds with *Move_Response* message.
- (11) Finally, NAP transmits *Reassociation_Response* to MN to notify that L2 handover is completed. MN has associated with the NAP and updated to new L2 address and BSS ID.
- (12) MN can receive *RA* message or send *RS* message to NAR through this new association. In this step MN gets NAR IP address and subnet prefix.
- (13) When MN recognizes NAR, it sends *Registration Request* message to the NAR to register itself on the visitor list.
- (14) NAR configures an NCoA for MN. In MIPv6 there are two modes for CoA configuration: stateless and stateful. First, in stateless mode the MN configures the NCoA based on prefix information from *RA* message. MN requests use of NCoA to NAR through *Registration Request*. Then NAR examines duplication of the address by some procedure like Duplicated Address Detection (DAD). NAR may or may not allow the request. Second, in stateful mode NAR uses the address allocation algorithm, like Dynamic Host Configuration Protocol for IPv6 (DHCPv6) and configures NCoA to MN.
- (15) NAR sends *Binding Update* message to HA of MN. The message includes information of NCoA and AAA for MN.
- (16) HA updates binding information for MN, decides AAA and binding lifetime, and sends *Binding Acknowledgement* message to NAR.
- (17) NAR delivers *Registration Reply* message to MN and allows the use of NCoA.

(18) Finally, MN starts to communicate with HA/CN using NCoA via NAR. The normal L3 handover procedure is completed.

In the above procedure L2 and L3 handovers start at step (7) simultaneously. Router discovery delay is the time period from step (7) to (13) and route reestablishment delay is the duration from step (14) to (19). When HA or CN is far away from MN, route reestablishment delay is a significant obstacle to delay and throughput-sensitive traffics with acceptable QoS.

3.2. Fast Handover Procedure for WLAN

In Section 2.1 Mobile IPv6 Fast Handover protocol is proposed to minimize service interruption experienced by MN as it changes its point of attachment to the Internet. An MN cannot send or receive packets when it is disconnected from PAR. The disconnection continues until the MN registers NCoA to NAR. Such an interruption would be unacceptable for real-time services such as Voice-over-IP. In this paper we propose a detailed procedure of Fast Handover for WLAN. In the proposed procedure L2 and fast L3 handovers are processed simultaneously.

Assume that MN is in infrastructure mode and the MN wants to change its association from its current AP to a new AP. In WLAN MN determines a new AP by detecting the beacon from the new AP. At this point the L2-ST or L2-MT is fired. When information about the new AP is announced to L2 of current AP or MN, L2 decides to fire triggers to L3 based on some criteria. After that, MN sends *Reassociation_Request* message to desired AP. The message contains MAC addresses of MN and current AP. On receipt of the message AP determines if MN can reassociate and replies with a *Reassociation_Reply* message by allowing or denying the request. At this point L2-TT is fired.

L2-LU delivered to MN triggers the stack to send *RS* to NAR. This causes NAR to reply with *RA*. Therefore, L2-LU can eliminate latency involved in waiting for *RA* beacon from AR and increases handover performance. However, L2-LD delivered to MN does not trigger any important L3 event. In the

Fast Handover *FBU* should be sent to PAR before previous link is disconnected or to NAR after new link is established.

Figure 5 shows detailed process of the Fast Handover for WLAN. We assume that the proposed Fast Handover procedure is based on the mobile initiated handover and stateful address autoconfiguration. Only additional steps are explained and presented in Figure 5 compared to the normal handover procedure given in Figure 4.

- (19) Assume that MN is informed a handover by L2-MT. The trigger has information that L2 handover is close. Then MN sends *RtSolPr* to PAR to initiate the Fast Handover. The message includes L2 identifier of NAP.
- (20) When PAR receives the message, it finds related NAR from its neighbor list based on the information about NAP. Then PAR sends *HI* to related NAR. *HI* initiates establishing a bi-directional tunnel between two ARs and requests to configure an NCoA for MN. In the Network Initiated Handover, PAR sends *HI* without *RtSolPr* from MN.
- (21) NAR configures NCoA with DHCPv6.
- (22) NAR sets up parameters related to the bi-directional tunnel like tunnel lifetime etc. and sends *HACK* to PAR with NCoA and parameters.
- (23) In response to *RtSolPr* PAR sends *PrRtAdv*, which provides L3 address of the NAR and NCoA.
- (24) After *PrRtAdv*, MN sends *FBU* to PAR when it decides the handover. This *FBU* message associates MN's PCoA with NAR's IP address so that packets arriving at PAR can be tunneled to NAR. That is, MN cannot receive any packets from PAR when it sends the *FBU* message.
- (25) When PAR receives *FBU*, it prepares packet tunneling, that is, binding PCoA with NAR's IP address. It sends an *FBACK* to the NAR. The *FBACK* confirms whether NCoA could be used. This step is run parallel with the L2 handover process.
- (26) Immediately upon attaching to the NAR, the MN sends an *RS* with *FNA* option in step (14). The

FNA includes the MN's PCoA and link-layer addresses and announces the MN's presence to the NAR. Then the NAR sends the *FBACK* to the MN to confirm the NCoA.

(27) Since the CN sends packets to the PAR with the PCoA that exists in a CN's binding cache for the MN, the PAR tunnels the packets to the MN with NCoA.

In normal handover, route reestablishment delay is the period from step (14) to step (19) in Figure 4. However, in the Fast Handover it is reduced from step (14) to step (28) of Figure 5. Thus, MN can support delay and throughput-sensitive service regardless of locations of HA and CN.

4. Triggers in WLAN and the Performance

In this section we propose triggers for the Fast Handover based on WLAN system. As mentioned in Section 2.3, the Fast Handover procedure fully depends on L2 triggers. Based on the basic features of triggers in Section 2.2 we introduce more detailed functions of triggers that are specific in WLAN system.

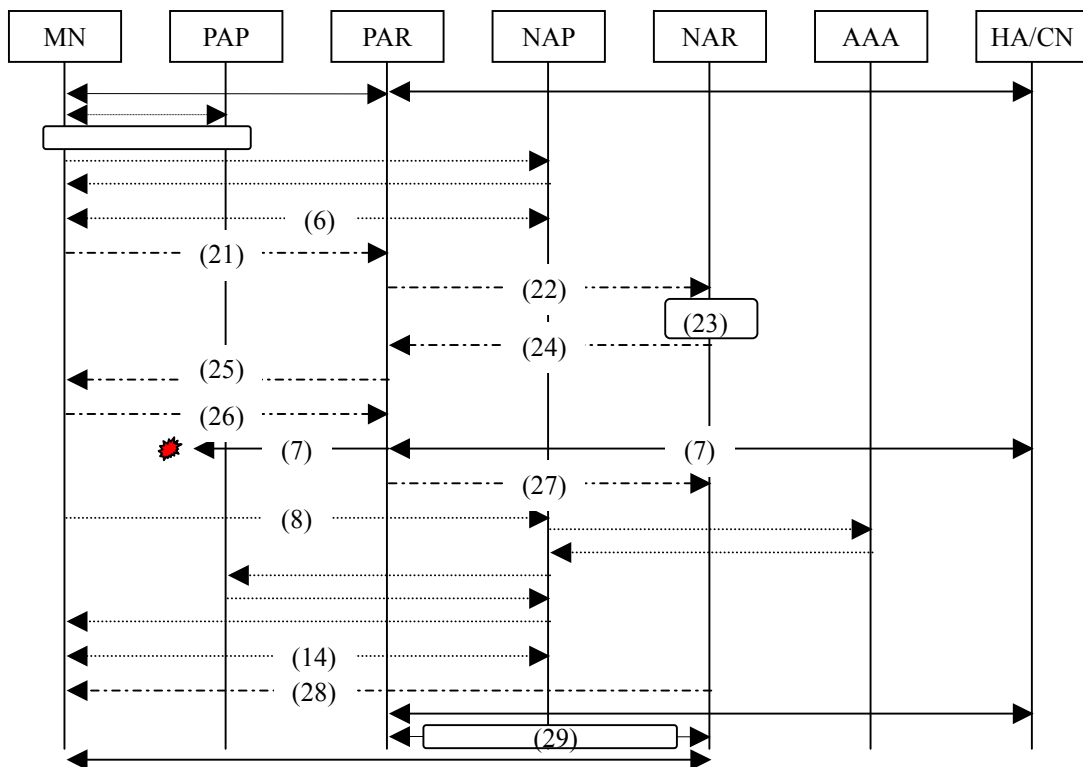

Figure 5 Fast Handover for WLAN

4.1. Two Performance Criteria for the WLAN

We propose two performance criteria for L2 triggers and L3 Fast Handover. First, L2 triggers should satisfy handover timeliness. It means that triggers should be generated with a margin appropriate to prepare the handover event. Figure 6 shows the timeliness for trigger that is related to T_1 threshold in step (3) of Section 3.1. Suppose that T_1^* is a proper threshold to prepare handover in the figure. Then either T_1^L or T_1^H is an inappropriate margin for the Fast Handover.

Second, L2 triggers should support the handover accuracy. That is, target AP of the handover must be selected correctly. Target AP is selected based on the signal strength threshold T_2 and the dwell time threshold T_3 as in step (5) of Section 3.1. Clearly, high signal strength T_2 causes difficulty in scanning of APs, while low T_2 makes selection of AP difficult. Also, short dwell time T_3 may lead to inaccurate AP selection, while long T_3 leads to waste of wireless resources.

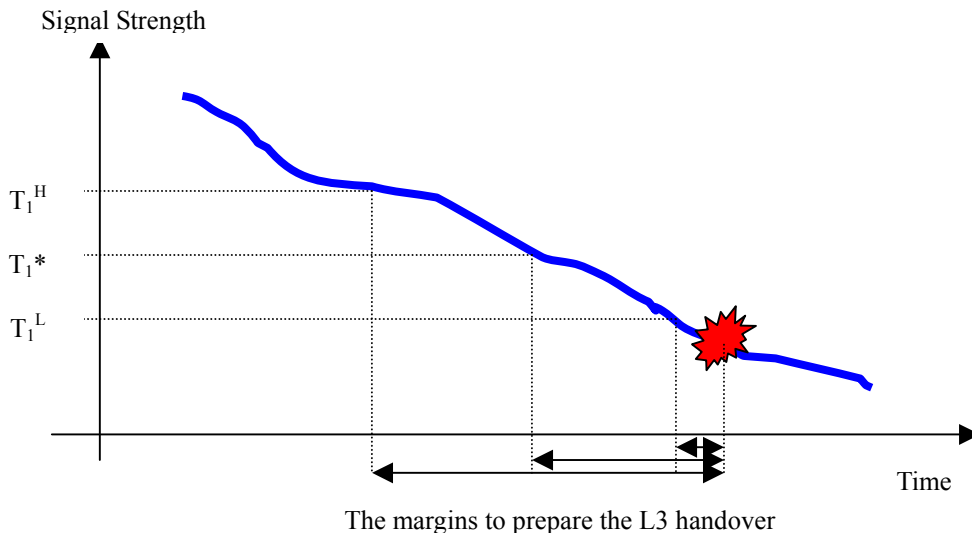

Figure 6 Handover Timeliness about the L2 triggers

4.2. L2 Triggers in WLAN System

L2-ST (Layer 2 Source Trigger)

L2-ST is created by L2 of PAR (i.e. PAP) and transmitted to L3 of PAR. L2-ST prepares information

exchange among L3 entities related to L3 handover. Because part of the exchange is through wireless link L2-ST must be fired sufficiently before L2 handover. L2-ST includes L2 address of NAP and information of IP address of NAR. Therefore L2-ST must be generated when the target AP is decided. Also, it has to be generated before step (7) in Figure 5. Consequently, L2-ST should be generated in step (6). That is, generated trigger is sent to PAR through existing link to prepare L3 Fast Handover when MN is sufficiently synchronized with NAP. Of course L2-ST should satisfy two performance criteria. When L2-ST is used, *RtSolPr* message of step (21) in Figure 5 is omitted.

L2-TT (Layer 2 Target Trigger)

Although L2-TT serves the same function as L2-ST, it is created by L2 of NAR (i.e. NAP) and transmitted to L3 of NAR. L2-TT prepares the same information exchange. However, link between the MN and NAP is connected in step (14) in Figure 5. It is too late to prepare L3 handover after step (14) because step (14) is the start point of L3 normal handover. To solve this problem we assume that MN can send the information to NAP without regular link between them. It is possible that MN sends its information to NAP in *Probe.Request* message through broadcast channel during synchronization. After receiving the message NAP fires L2-TT. Since L2-TT should have L2 addresses of MN and PAP, the message may have significant security problems. When L2-TT is used, *RtSolPr* message is omitted and *HI* and *HACK* messages are changed to reverse direction in Figure 5.

L2-MT (Layer 2 Mobile Trigger)

L2-MT is created by L2 of MN and transmitted to its L3. Since the L2-MT supports MN to decide the handover, L2-MT is necessary when mobile initiated handover is applied. As in Figure 5 the Fast Handover using L2-MT needs the longest margin to prepare L3 handover. When L3 of MN decides handover, L3 sends *RtSolPr* message to PAR with the information of the MN and NAP. L2-MT allows MN to initiate construction of a bi-directional tunnel between PAR and NAR before L2 handover. Compared to the network-initiated handover mobile-initiated handover is advantageous in view of

implementation. The difficulty of network-initiated handover is mainly due to the modification of routers and correct prediction of MN's movement. Since network (or routers) should be informed of the movement (or received signal strength) of MN passively, prediction information to the network is further delayed. Thus we recommend handover by L2-MT for accurate prediction in WLAN.

L2-LU (Layer 2 Link Up)

L2-LU is transmitted to MN or NAR to notify the establishment of L2 wireless link between MN and NAP. This trigger carries L2 information of MN and NAP. In WLAN MN should associate with one and only one AP [5, 6]. Thus the trigger may be fired when previous wireless link is disconnected in step (13) of Figure 5. Since L2-LU is fired after the new wireless link the timeliness and accuracy of the Fast Handover is guaranteed.

L2-LD (Layer 2 Link Down)

L2-LD is transmitted to MN or PAR to notify disconnection of L2 wireless link between MN and PAP. This trigger carries L2 information of MN to PAR. In WLAN MN disassociates with previous AP by sending *Move.Request* message via the new AP [6]. Thus the trigger may be fired after the message is delivered to PAP in step (11) of Figure 5. The main purpose of L2-LD is the release of wired and wireless resources for MN at PAR and PAP. For that purpose L2-LD should be fired at earlier time than step (11) because wired and wireless resources are not required after step (7). In the Fast Handover MN transmits *FBU* message to PAR for the same purpose. Since *FBU* is transmitted through wireless link, it cannot be triggered by L2-LD. Thus, L2-LD is unnecessary in the Fast Handover for WLAN.

4.3. Implementation of Fast Handover in WLAN

For implementation of the proposed Fast Handover in WLAN we suggest mobile-initiate Fast Handover with L2-MT. What is important in implementation is to predict L2 handover and to fire trigger in an appropriate time. Since the procedures for L3 handover preparation such as exchange of control

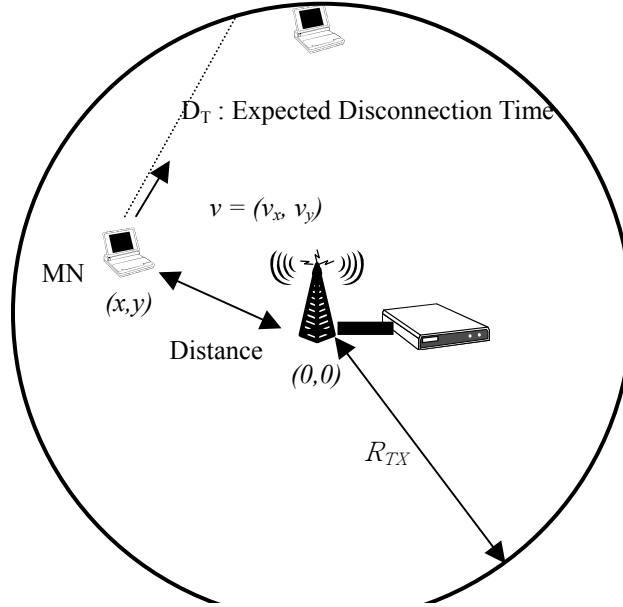

Figure 7 L2 Handover Prediction

messages and CoA allocation require a fixed duration, the trigger can be easily fired if MN has exact information about L2 handover. To correctly predict L2 handover a precise disconnection time of current wireless link need to be computed. Based on mobility parameters such as speed, direction, and transmission range, the duration of connection time between MN and PAP can be determined. Figure 7 shows L2 handover prediction when MN located at (x, y) moves with the speed of $v = (v_x, v_y)$. Assume the transmission range of AP be R_{TX} . Then, the following equation holds [12].

$$(x + D_T v_x)^2 + (y + D_T v_y)^2 = R_{TX}^2$$

From this equation the disconnection time D_T is computed as in follows [12].

$$D_T = \frac{-(xv_x + yv_y) + \sqrt{(x^2 + y^2)R_{TX}^2 - (xv_y - yv_x)^2}}{(x^2 + y^2)}$$

For more accurate disconnection time mobility parameters have to be updated periodically. If MN is sufficiently intelligent, the prediction can be easily implemented.

5. Computational Results

We test the effects of MN's mobility parameters in the proposed Fast Handover and simulate handover procedures. The simulation is run on 850 MHz Intel Pentium III personal computer with 256 Mbytes of memory under Linux Redhat 7.0. The simulation is based on MobiWan which is a simulation tool based on NS (version ns-2.1b6) with Mobile IPv6 under LAN [13]. We assume 18 cells (APs) with 100-meter radius, six ARs, one Gateway, and one AAA server as in Figure 1. The speed of MN is varied in the range of [1 Km/h, 50 Km/h]. Two performance measures are considered: handover timeliness and handover accuracy. The three pre-handover-triggers: L2-ST, L2-TT, and L2-MT are tested in the simulation.

5.1. Handover Timeliness

Let C_T be the cost measure of the handover timeliness. The cost is represented by the weighted sum of the earliness and tardiness of each trigger.

$$C_T = P_E(H - X)^+ + P_T(X - H)^+$$

In the above equation H represents time duration from fire of the trigger to start of the L2 handover. The time period X spent on preparing L3 Fast Handover, is duration from fire of the trigger to start of the packet tunneling. P_E and P_T respectively are the penalties of earliness and tardiness of trigger.

When the handover is early prepared, PAR sends packets for MN to NAR. In this earliness case, $H > X$, packets are transmitted through tunnel between PAR and NAR instead of wireless link which is still connected. Fast Handover procedure may prevent transmitting packets for MN directly. Therefore, $H - X$ is unnecessarily delayed time that MN waits to receive packets. Thus, the link throughput between CN and MN is degraded. When the handover is tardy, tunnel is not constructed, but handover starts. In this tardiness case, $X > H$, Fast Handover procedure fails. MN does not know whether the tunnel is connected or not. MN has not received valid NCoA because previous wireless link is disconnected. Therefore, MN tries to get a new CoA and routing path between MN and HA/CN as in the normal handover procedure.

The dynamic movement of MN causes handover prediction error. Since the error prevents pre-

handover trigger being fired in appropriate time, MN's movement parameters affect the handover timeliness problem. In the simulation for handover timeliness we assume that MN moves straight and changes its speed dynamically. That is, MN changes its speed within a domain, but it does not change its direction of moving. With this model we can analyze effects of speed variation to handover timeliness cost.

Suppose that MN's speed varies every time unit. Let $v(t)$ be the speed at time t . At time $t+1$ the speed is increased or decreased by $100 \times \beta$ % with probability α_1 . Then the speed variation is represented by the following equation.

$$v(t+1) = \begin{cases} (1 + \beta)v(t) & \text{with probability } \alpha_1 \\ (1 - \beta)v(t) & \text{with probability } \alpha_1 \\ v(t) & \text{with probability } 1 - 2\alpha_1 \end{cases}$$

Figure 8 shows effects of α_1 to the handover timeliness cost. In the figure, as the probability α_1 increases, handover timeliness becomes worse. When the probability exceeds 0.2, L2-TT outperforms other procedures. However, triggers have no gap in performance when the probability is small. In this simulation the time unit is set to 100 ms, that is, MN changes its speed 10 times in every second. Three

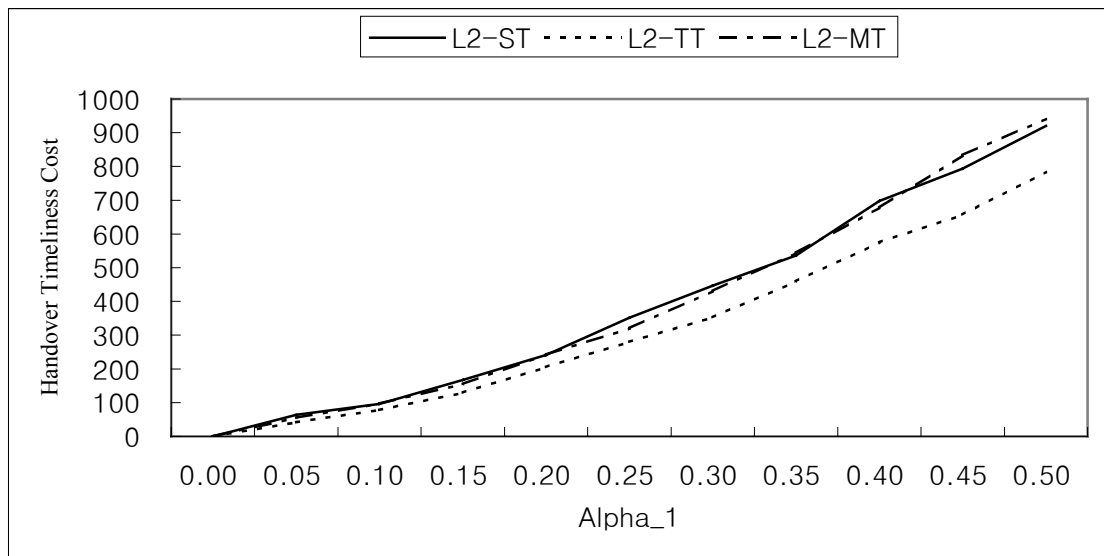

Figure 8 Handover Timeliness with speed change probability α_1

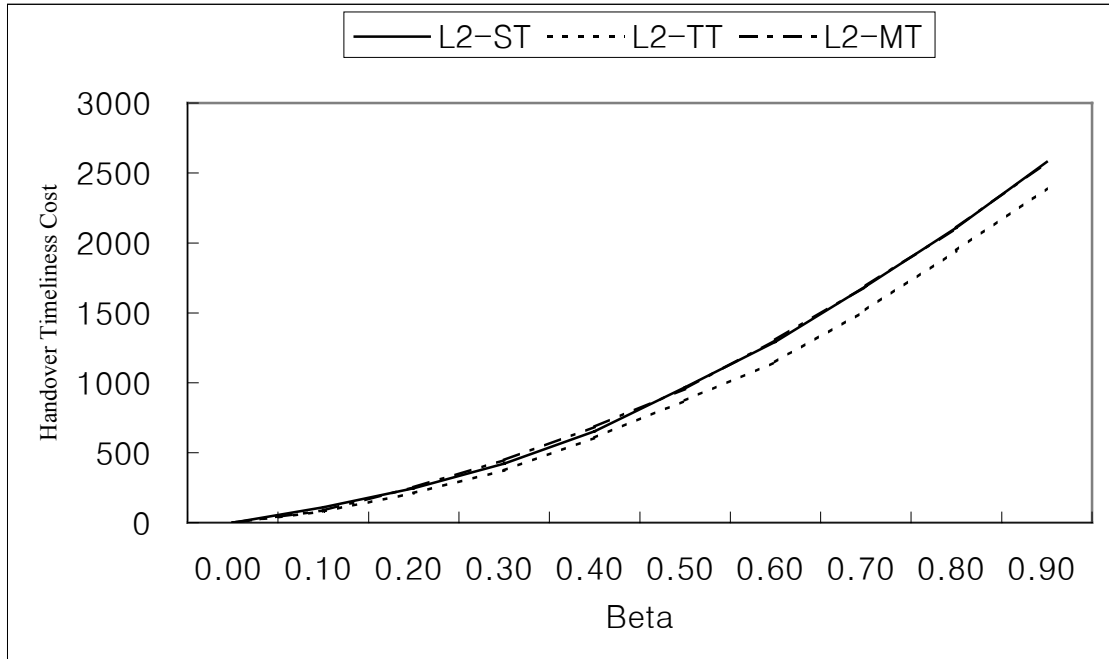

Figure 9 Handover Timeliness with speed change β

Figure 9 shows the effects of β . Almost same trend is illustrated as in Figure 8. As the range of MN's pre-handover-triggers demonstrate same performance in the real environment, speed variation increases, the handover timeliness becomes worse. The performance of three triggers has no big difference. However, the speed change has higher effect on the handover timeliness than the speed variation probability.

5.2. Handover Accuracy

Let C_A be the cost measure of the handover accuracy. The cost is represented by the product of opportunity cost and delay as follows.

$$C_A = P_O \times D_N$$

In the above equation D_N represents duration that wrong AR/AP reserves system resource for MN. Because PAR of MN sends *HI* message to wrong AR, AR prepares MN's handover, allocates a CoA, and reserves wired and wireless bandwidth. This wrong matching results in opportunity cost for other mobiles.

P_o represents the opportunity cost per unit time.

Now we consider handover prediction error due to dynamic movement of MN. Since the error prevents pre-handover trigger being fired to appropriate target, MN's movement parameters affect handover accuracy. Also the trigger may send wrong information to PAR and improper AR. In the simulation we assume random walk travel model in which MN changes its direction, but does not change its speed of moving. We analyze effect of the direction change to handover accuracy cost.

Suppose that MN's direction can change at every time interval. Let $d(t)$ be direction at time t . At time $t+1$ the direction is changed 30° right or left with probability α_2 . Then the direction variation is represented by the following equation.

$$d(t+1) = \begin{cases} d(t) + \pi / 6 & \text{with probability } \alpha_2 \\ d(t) - \pi / 6 & \text{with probability } \alpha_2 \\ d(t) & \text{with probability } 1 - 2\alpha_2 \end{cases}$$

Figure 10 shows handover accuracy cost by changing direction with probability α_2 . In the figure, the handover accuracy performance is degraded as the probability is increased. The handover accuracy cost depends largely on the mobile speed. When the speed is 30 Km/h with high probability of direction change the performance drops dramatically.

5.3. Comparison of Normal and Fast Handover Procedures

In this section we compare normal and Fast Handover procedures in WLAN. Figure 11 and 12 show the delay distribution of two handover procedures. Delay is composed of sum of probe delay, reassociation delay, and route reestablishment delay. The probe delay is time that MN probes target AP of handover that corresponds to the time from step (2) to step (7) in Figure 4. If overlapped transmission region between PAP's and NAP's exists, the probe procedure is not included in handover procedure. The reassociation delay is part of router discovery delay. It is the duration from step (8) to step (13) in the figure. Since

probe delay and reassociation delay are related to L2 handover, there is no difference between two handover procedures. However, the route reestablishment delay is reduced to 80 ~ 90% by the Fast Handover. Consequently, the total handover delay by the Fast Handover is reduced to 20 ~ 25 % of the normal delay.

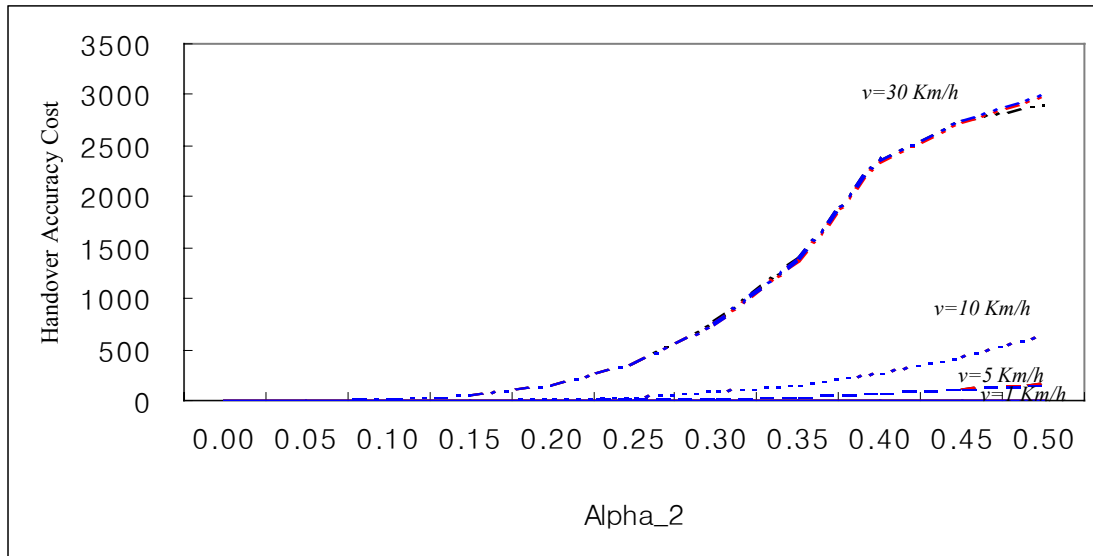

Figure 10 Handover Accuracy with direction change probability α_2

6. Conclusion

Fast Handover procedure is presented in Mobile IPv6 to support real-time and throughput-sensitive applications. To reduce handover latency fast wireless connection between MN and NAR is established by considering both L2 and L3 handovers. The Fast Handover discussed for Wireless LAN is based on L2 triggers. The performance of triggers is analyzed in view of handover timeliness and accuracy. Almost same performance is obtained by three pre-handover-triggers in the real environment. Although L2-TT outperforms other methods in some special environment, it has security and unique association problems. We recommend L2-MT as the best trigger in WLAN. The Fast Handover reduces the route reestablishment delay by 80 ~ 90 % compared to the normal handover. As the result of that the Fast Handover reduces the total handover delay by 20 ~ 25 %.

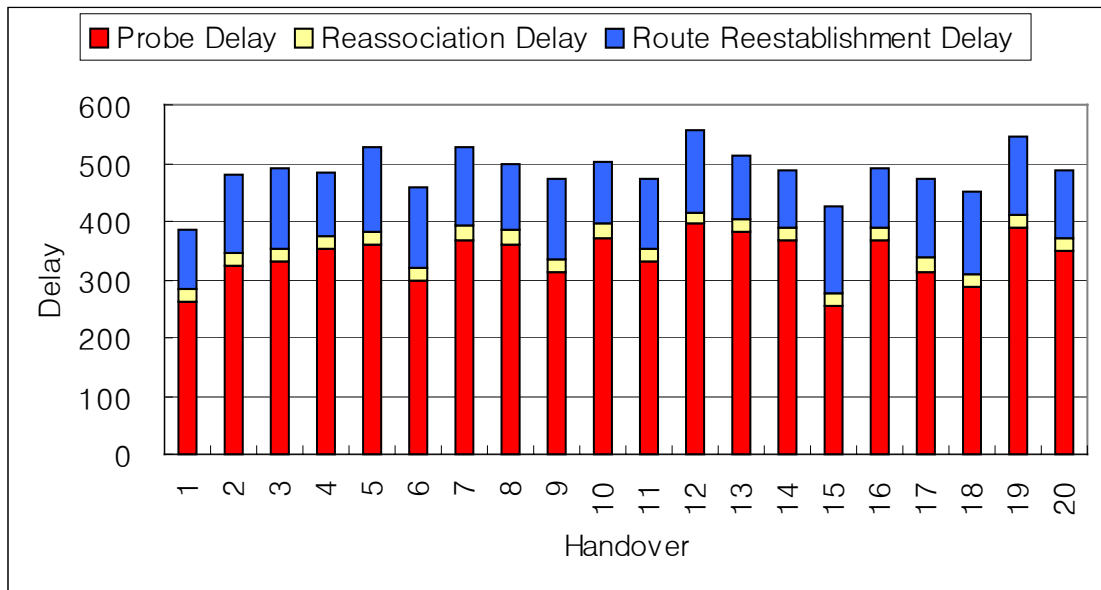

Figure 11 Normal Handover Delay

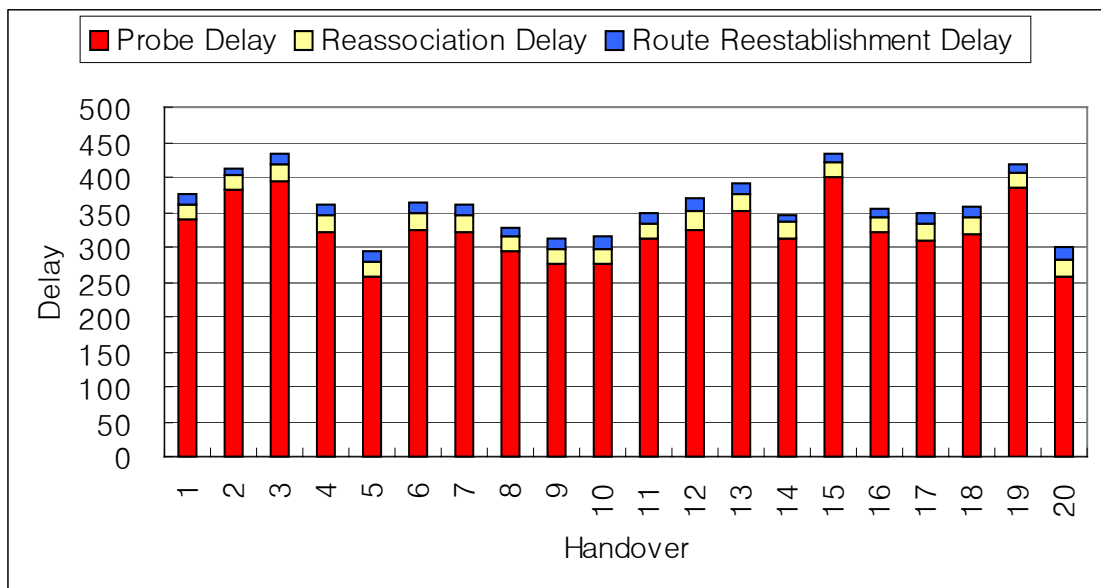

Figure 12 Fast Handover Delay

References

- [1] <http://www.ietf.org/html.charters/mobileip-charter.html>
- [2] Johnson, D., C. Perkins and J. Arkko. 2003. Mobility Support in IPv6 (work-in progress). draft-ietf-mobileip-ipv6-21.txt.
- [3] Dommety, G. 2003. Fast Handovers for Mobile IPv6 (work-in progress). draft-ietf-mobileip-fast-mipv6-06.txt.
- [4] Yegin, A. 2002. Supporting Optimized Handover for IP Mobility - Requirements for Underlying Systems. draft-manyfolks-l2-mobilereq-02.txt.
- [5] IEEE Std. 802.11b. 1999. Wireless LAN Medium Access Control (MAC) and Physical Layer (PHY) Specifications: Higher-Speed Physical Layer Extension in the 2.4 GHz Band.
- [6] IEEE Std. 802.11f/D3.1. 2002. Recommended Practice for Multi-Vender Access Point Interoperability via an Inter-Access Point Protocol Across Distribution Systems Supporting IEEE 802.11 Operation.
- [7] Goswami, S. 2002. Simultaneous Handoff of Mobile IPv4 and 802.11. draft-goswami-mobileip-simultaneous-handoff-v4-01.txt.
- [8] McCann, P. 2002. Mobile IPv6 Fast handovers for 802.11 Networks. draft-mccann-mobileip-80211fh-01.txt.
- [9] Hsieh, C.C., C.T. Chang. 2001. An Enhanced Transaction Identification Module on Web Usage Mining. Asia Pacific Management Review 6(2) 241-252.
- [10] Kim, Y.S., B.J. Yum. 2002. Identification of Navigational Paths of Users Routed through Servers for Web Usage Mining. Asia Pacific Management Review 7(4) 497-510.
- [11] Othman, R. 2001. Antecedents and Outcome of IT use: How does HRM fit in? Asia Pacific Management Review 6(1) 91-104.
- [12] Lee C.Y., H.G. Kang. 2000. Performance of the Double Tunneling with Handoff Prediction in Mobile IP Network. Proceedings of Wireless 2000.
- [13] The MobiWan Project, <http://www.inrialpes.fr/planete/mobiwan/>