

# A Modularized Two-Stage Charge Equalization Converter for Series Connected Lithium-Ion Battery Strings

Chol-Ho Kim \*, Hong-Sun Park \*, and Gun-Woo Moon \*

Dept. of EE, Korea Advanced Institute of Science and Technology, Daejeon, Republic of Korea

## Abstract

This paper proposes a modularized two-stage charge equalization converter for a series-connected lithium-ion battery string. In this paper, the series-connected battery string is modularized into  $M$  modules, and each module has  $K$  cells in series. With this modularization, low voltage stress on the electronic devices can be achieved. A two-stage dc-dc converter with cell selection switches is employed. The first stage dc-dc converter steps down the high bus voltage to about 10 V. The second stage dc-dc converter integrated with selection switches equalizes the cell voltages. A prototype for 88 lithium-ion battery cells is optimally designed and implemented. Experimental results verify that the proposed equalization method has good cell balancing performance showing low voltage stress, small size, and low cost.

## 1. Introduction

Recently, Series connected battery strings have been used for many practical applications such as electric vehicles (EVs), hybrid electric vehicle (HEV), uninterruptible power supplies (UPS), and space applications [1]. In many applications, the series-connected battery string is normally used to achieve a high voltage for an input source. However, repetitive battery charging and discharging can cause a charge imbalance among the battery cells. The problem associated with this phenomenon is that this charge imbalance will decrease the total storage capacity and whole life cycle of the battery [2],[3]. Hence, charge equalization for a series-connected battery string is necessary to maintain the storage capacity and to extend the lifetime.

The recent development of lithium-ion battery shows good characteristics; the higher power, higher energy density, a lower self-discharge rate, and higher single cell voltage, such that an electric application using this lithium-ion battery comes into the spotlight in the future market. However, when the lithium-ion battery is applied in a practical power source as the battery string, it would have a higher risk of explosion during an overcharge state. Moreover, overdischarge of a battery cell can harm the battery's chemical and, in the worst case, explosion or fire [2],[3]. Therefore, charge equalization for series-connected lithium-ion batteries is very important.

Charge equalization methods for a series-connected battery string have been presented in [4]-[11] and well summarized in [12]. One of them is a dissipative method such as charge shunting. This method has a merit of simple implementation and low production cost, but energy dissipation is a major drawback. To obtain more efficient charge balance, a multi-winding transformer based equalizer is presented in [4]-[7]. In these methods, the low production cost and the simple structure of a controller are main advantages. However, these techniques show the implementation problem of multiple secondary windings equal to the number of cells.

To escape the above defects, cell control based equalizers are

discussed in [8]-[11]. These methods allocate the separated dc-dc converter to each cell, such that the implementation and individual control of equalization current are easily achieved. However, these schemes have a problem of large size and high cost for a large number of lithium-ion batteries.

This paper proposes a modularized two-stage charge equalization converter. In the proposed equalizer, each module has a shared dc-dc converter. With this configuration, the size and cost problem is effectively solved. Moreover, the modularized battery cells archive low voltage stress on the electric devices. In this paper, a prototype of 88 lithium-ion battery cells is implemented and its experimental results are presented.

## 2. Proposed Charge Equalization Converter

### 2.1 Circuit Description

Fig. 1 shows the block diagram of the proposed charge equalization converter applied to  $M \times K$  battery cells. In this paper, the battery string is modularized into  $M$  groups, and each group has  $K$  cells.

The proposed equalizer consists of three parts; the first stage dc-dc converter, the second stage dc-dc converter, and selection switch modules. The first stage converter steps down high voltage of the battery string to about 10 V. This stage is simply implemented by using the conventional flyback converter. The main work of this stage is to supply equalization power to the second stage modules. The second stage converter, constructed in each module, does make the charging current. The second stage is also constructed by the flyback converter. Lastly, the selection switch module consists of the bi-directional MOSFET to make a current path between the second stage dc-dc converter and the selected battery cell.

### 2.2 Operational Principles

In the proposed charge equalizer, charge balance is archived by transferring the equalization current, which is extracted from the overall battery string, to the undercharged cells. To make this process, the proposed equalizer employs a battery management controller (BMC) with voltage sensing circuitry. The battery management controller collects the sensing data from the sensing circuit and determines the operating of the charge equalization in the battery strings. Then, it drives the charge equalizer with three consecutive steps. Before describing these three steps, it is assumed that the second battery of the third module,  $B_{3,2}$ , is undercharged.

- Step 1: When the battery management controller turns on the bi-directional switches,  $S_{3,2a}$  and  $S_{3,2b}$ , by using the opto-couplers,  $Q_{3,2a}$  and  $Q_{3,2b}$ , the first step starts. In this step, the current path for  $B_{3,2}$  is constructed. As shown in Fig. 2 (a), the charge current can flow into  $B_{3,2}$  through this current path.

There are two kinds of techniques to turn on the bi-directional switch. As shown in Fig. 3, an N-channel MOSFET switch can be turned on by using the upper layer batteries,  $B_{3,k-2}$ ,  $B_{3,k-1}$ ,  $B_{3,1}$ , and  $B_{3,2}$ . On the other hand, a P-channel MOSFET switch can be

turned on by using the lower layer batteries,  $B_{1,1}$ ,  $B_{1,2}$ ,  $B_{1,3}$ , and  $B_{1,4}$ .

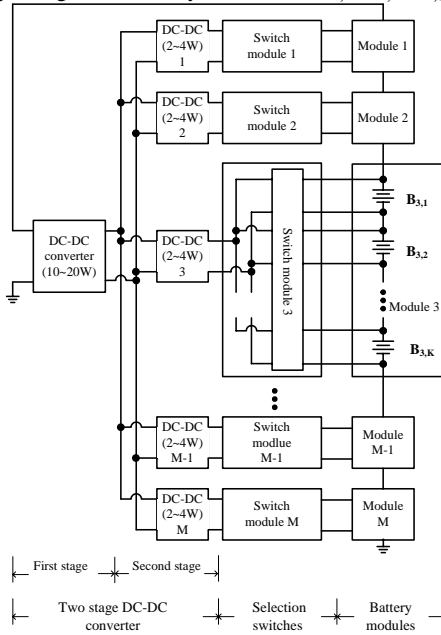

Fig. 1. Block diagram of the proposed two-stage charge equalizer.

This P-channel MOSFET switches are used only for two cells of the first module,  $B_{1,1}$  and  $B_{1,2}$ .

- Step 2: After complete turn-on of the bi-directional switches, the second stage dc-dc converter is driven by the BMC. As a result, this second stage converter is now coupled with  $B_{3,2}$  as shown in Fig. 2(b). In this mode, although the second stage converter operates, the equalization current does not flow into selected cell. This is because the first stage is not turned on, such that the second stage has no input power yet.

- Step 3: In this mode, the first stage dc-dc converter is turned on by the BMC. This stage transfers the equalization current from the battery stack to the input terminal of the second stage converter. Therefore, by collaborating on the second stage dc-dc converter with the selection switch mode, the first stage converter can provide the equalization current to  $B_{3,2}$  as shown in Fig. 2(c).

### 3. The Power Rating Design Scheme

This section presents the optimal power rating design guide for a charge equalization converter. The power rating of an equalization circuit has a close relation with the equalization time; that is, the higher the power rating, the shorter the equalization time. The power rating is also related to the size of the circuit. Hence, we employ a way of determining the power rating while achieving cell balance within the desired equalization time [10],[11].

The proposed charge equalizer is applied to a lithium-ion battery string of 88 cells, where only one cell is assumed to be undercharged. To obtain the optimal power rating for this environment of the battery string, the following simultaneous equations should be satisfied:

$$\frac{1}{87} \sum_{n=2}^{n=88} Q_n(t) = Q_N(t) \quad (1)$$

$$P_{out,avg} = \eta \cdot P_{in,avg} \quad (2)$$

where the left side of (1) is the average charge quantity of the overall batteries except the undercharged cell at equalization time  $t$ , and the right side is the charge quantity of the undercharged battery cell at equalization time  $t$ .

Equation (2) indicates the relation between the input power and the output power of the proposed equalizer with efficiency of  $\eta$ .

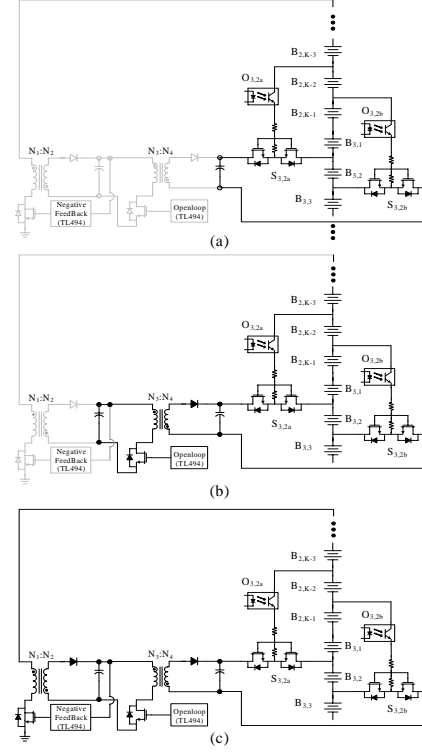

Fig. 2. Operational principles of the proposed circuit.

(a) Step 1. (b) Step 2. (c) Step 3.

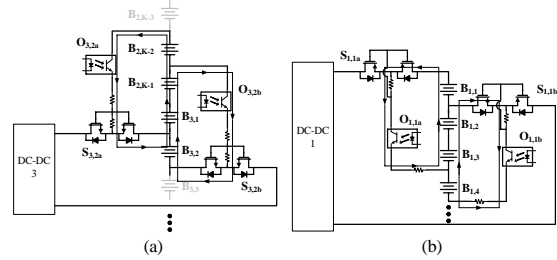

Fig. 3. Turn-on process of selection switches. (a) In case of N-channel MOSFET. (b) In case of P-channel MOSFET.

The input power means the equalization power which is extracted from the whole battery stack, and the output power means the equalization power which flows into the undercharged cell.

Fig. 4 shows simulation results of the power rating design guide. In this simulation, it is assumed that only one cell is undercharged and the SOC gap between the undercharged cell and the other cells is 10%. Moreover, the efficiency of the proposed equalizer is temporarily assumed to be 50%, 60%, and 70%. The equalization time is plotted in relation to the input current of the equalizer and the net current into the undercharged cell. From the simulation results, we know that the shorter equalization time will be taken for the higher input current of equalizer and also the higher net current. In addition, the higher efficiency of equalizer takes the smaller input current. As one design example, to obtain charge balance within 100 minutes, input current of about 0.011 A is required at an efficiency of 50%. Then, the net equalization current is 0.45 A.

### 3. Experimental Results

To show the feasibility of the proposed modularized two-stage equalizer, a prototype for 88 cells was implemented. Fig. 5 shows the photograph of the prototype. It is noted that the proposed equalizer is realized with two boards; thus, each board takes care of 44 cells. As shown in Fig. 5, the balancing circuit and the battery management controller are implemented on the same board.

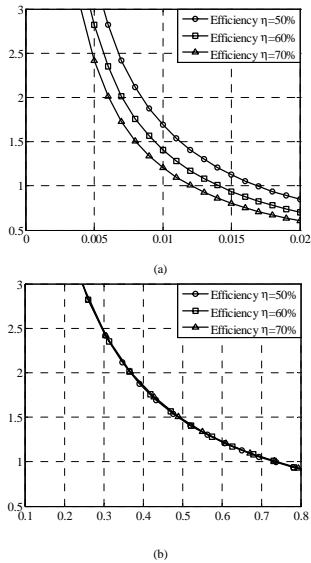

Fig. 4. Simulation results of the optimal power rating design under the SOC gap of 10%. (a) Equalization time vs. input current. (b) Equalization time vs. net current.

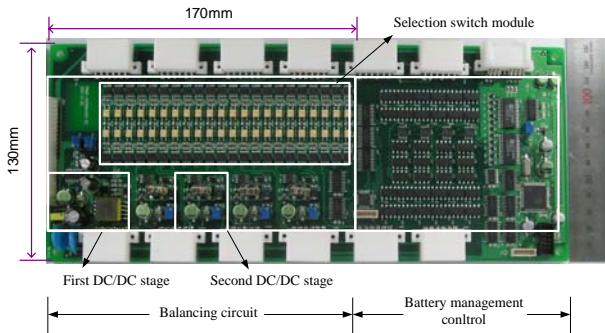

Fig. 5. The photograph of an implemented engineering prototype for 88 lithium-ion battery cell.

The proposed balancing circuit occupies approximately 55% of the overall board size (130 x 310 mm).

To verify the cell balancing performance of the proposed charge equalizer, we conducted an equalization test. The battery SOC distribution is as follows. The SOC of the most undercharged cell,  $B_{3,2}$  is 26%, and the SOC of the remained cells is 36.5%; thus, approximately 10% SOC gap is made.

The control strategy of the BMC is two steps. The first step is to find the most undercharged cell and then, drives the proposed equalizer based on the simulation results as shown in Fig. 4.

Fig. 6 shows the equalizer performance of the proposed equalizer. After the BMC drive the equalizer during 100 minutes, charge balance is achieved. The SOC gap decrease from 10% to approximate 1%, which value is equivalent to about 6 mV. The net equalization current is measured to 0.49 A. It is noted that this experimental results are very similar to that of the simulation result shown in Fig. 4.

#### 4. Conclusions

In this paper, a modularized two-stage charge equalization converter for lithium-ion battery cells was proposed, and a prototype was implemented. In proposed circuit, by applying a battery modularization concept and a two-stage equalizer, we achieve the low voltage stress of the entire electric device except the primary switch of the first stage. Moreover, by sharing the second stage dc-dc converter among the battery strings within module, the proposed equalizer solves a size and cost problem

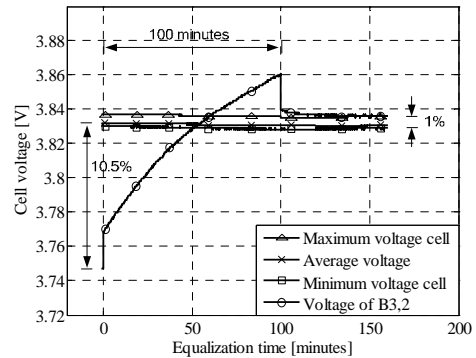

Fig. 6. The result of cell equalization test for 88 lithium-ion battery cells.

effectively. Therefore, the proposed two-stage equalizer can be used widely for a high stack of lithium-ion battery cells.

#### Acknowledgment

This work was supported by the STSAT-3 program of the Korea Aerospace Research Institute (KARI) grant funded by the Korea Ministry of Education, Science and Technology (MEST).

#### Reference

- [1] D. S.- Repila and J. E. W. Poxon, "Hybrid electric vehicles: current concepts and future market trends," *J. Barcelona IEEE Student Branch*, vol. 13, pp. 5-30, Mar. 2006.
- [2] N. Takeda, S. Imai, Y. Horii, and H. Yoshida, "Development of high-performance lithium-ion Batteries for hybrid electric vehicles," *Mitsubishi Motors Technical Review*, pp. 68-72, Jan. 2003.
- [3] B. T. Kuhn, G. E. Pitel, and P. T. Krein, "Electrical properties and equalization of lithium-ion cells in automotive applications" in *Proc. 2005 IEEE Vehicle power and Propulsion Conf.*, Chicago, USA, Sep. 2005, pp. 55-59.
- [4] N. H. Kutkut, H. L. N. Wiegman, D. M. Divan, and D. W. Novotny, "Design considerations for charge equalization of an electric vehicle battery system," *IEEE Trans. Ind. Appl.*, vol. 35, pp. 28-35, Feb. 1999.
- [5] D. M. Divan, N. H. Kutkut, D. W. Novotny, H. L. Wiegman, "Battery charging using a transformer with a single primary winding and plural secondary windings," U.S. Patent 5 659 237, Aug. 19, 1997
- [6] M. Tang and T. Stuart, "Selective buck-boost equalizer for series battery packs," *IEEE Trans. Aerosp. Electron. Syst.*, vol. 36, pp. 201-211, Jan. 2000.
- [7] Y. Xi and P. K. Jain, "A forward converter topology with independently and precisely regulated multiple outputs," *IEEE Trans. Power Electron.*, vol. 18, pp. 648-658, March. 2003.
- [8] Y. -S. Lee and M. -W. Cheng, "Intelligent Control battery equalization for series connected lithium-ion battery strings," *IEEE Trans. Ind. Electron.*, vol. 52, pp. 1297-1307, Oct. 2005.
- [9] Y. -S. Lee and G. -T. Cheng, "Quasi-resonant zero-current-switching bidirectional converter for battery equalization applications," *IEEE Trans. Power Electron.*, vol. 21, pp. 1213-1224, Sept. 2006.
- [10] H. -S. Park, C. -E. Kim, G. -W. Moon, J. -H. Lee, and J. K. Oh, "Charge Equalization with Series Coupling of Multiple Primary Windings for Hybrid Electric Vehicle Li-ion Battery System," in *Proc. IEEE PESC '07*, Orlando, USA, June 2007, PP. 266-271.
- [11] H. -S. Park, C. -E. Kim, G. -W. Moon, J. -H. Lee, and J. K. Oh, "Two-stage cell balancing scheme for hybrid electric vehicle Lithium-ion battery strings," in *Proc. IEEE PESC '07*, Orlando, USA, June 2007, PP. 273-279.
- [12] S. W. Moore and P. J. Schneider, "A review of cell equalization methods for lithium ion and lithium polymer battery systems," in *Proc. SAE '01 World Congress*, Detroit, USA, Mar. 2001, Doc. No 2001-01-0959.